



Logic HE™ Range

Balanced Flue Log Effect



Instructions for Use, Installation and Servicing

For use in GB, IE (Great Britain and Republic of Ireland)

IMPORTANT

THE OUTER CASING, FRONT AND GLASS PANEL BECOME EXTREMELY HOT DURING OPERATION AND WILL RESULT IN SERIOUS INJURY AND BURNS IF TOUCHED. IT IS THEREFORE RECOMMENDED THAT A FIREGUARD COMPLYING WITH BS 8423 (LATEST EDITION) IS USED IN THE PRESENCE OF YOUNG CHILDREN, THE ELDERLY OR INFIRM.

This product contains a heat resistant glass panel. This panel should be checked during Installation and at each servicing interval. If any damage is observed on the front face of the glass panel (scratches, scores, cracks or other surface defects), the glass panel must be replaced and the appliance must not be used until a replacement is installed. Under no circumstances should the appliance be used if any damage is observed, the glass panel is removed or broken.

It is essential that ALL of the screws that retain the glass frame are replaced and tightened correctly. Under no circumstances should the appliance be operated if any of these screws are loose or missing.

These Instructions must be left with the appliance for future reference and for consultation when servicing the appliance. Please make the customer aware of the correct operation of the appliance before leaving these instructions with them.

The commissioning sheet found on Page 3 of this Instruction manual must be completed by the Installer prior to leaving the premises.

PR2756.5.04.2026

CONTENTS

LOGIC HE - BALANCED FLUE

Covering the following models:

GAS TYPE	LOGIC HE BF	
	REMOTE CONTROL	SLIDE CONTROL
Nat Gas	101-014	101-281
LPG	101-666	101-516

Appliance Commissioning Checklist3

User Instructions4

Installation Instructions 16

Technical Specifications 16

Site Requirements 19

Installation 22

Commissioning 34

Service Requirements35

Fault Finding..... 35

Service..... 39

Spare parts list 47

Information Requirement - Gas Heaters 51

Service Records 53

WARNING



In the event of a gas escape or if you can smell gas, please take the following steps:

- Immediately turn off the gas supply at the meter/emergency control valve
- Extinguish all sources of ignition
- Do not smoke
- Do not operate any electrical light or power switches (On or Off)
- Ventilate the building(s) by opening doors and windows
- Ensure access to the premises can be made

Please report the incident immediately to the National Gas Emergency Service Call Centre on 0800 111 999 (England, Scotland and Wales) , 0800 002 001 (N. Ireland) or in the case of LPG, the gas supplier whose details can be found on the bulk storage vessel or cylinder.

The gas supply must not be used until remedial action has been taken to correct the defect and the installation has been recommissioned by a competent person.



It is a requirement of the Building Regulations 2010 that the installation of this appliance is notified to the Local Authority. It is the responsibility of the GasSafe registered installer to carry out this notification to the Local Authority via the GasSafe register Competent Persons Scheme in England and Wales (different rules apply in Scotland and Northern Ireland).

When the installation has been notified, GasSafe will send a Building Regulations Compliance Certificate to you containing details of the work completed. Please ensure that the person responsible for the installation of this appliance completes this notification and records it in the Appliance Commissioning Checklist on Page 3.

IT IS YOUR RESPONSIBILITY TO COMPLY WITH THE BUILDING REGULATIONS AND BE ABLE TO PRODUCE THIS CERTIFICATE SHOULD IT BE REQUIRED IN THE FUTURE.

APPLIANCE COMMISSIONING CHECKLIST

To assist us in any guarantee claim please complete the following information:-

IMPORTANT NOTICE

Explain the operation of the appliance to the end user, hand the completed instructions to them for safe keeping, as the information will be required when making any guaranteed claims.

FLUE CHECK	PASS	FAIL
1. Flue Is correct for appliance		
2. Flue flow Test		
3. Spillage Test		
GAS CHECK		
1. Gas soundness & let by test		
2. Standing gas pressure	mb	
3. Appliance working pressure (on High Setting) Minimum Pressure Requirement: NG - 17.5mbar LPG - 34.5mbar NB All other gas appliances must be operating on full	mb	
4. Gas rate	m ³ /h	
5. Does Ventilation meet appliance requirements?		
SAFETY CHECK		
1. Check soundness of the Thermocouple connections - including tightness and lead integrity		
2. Glass checked to ensure no damage, scratches, scores or cracks		
3. Glass frame secured correctly and all screws replaced		
4. CO alarm fitted		
BUILDING CONTROL NOTIFICATION		
1. Installer notified GasSafe/Local Authority of installation via Competent Persons Scheme?	YES	NO

RETAILER AND INSTALLER INFORMATION

Retailer.....

.....

.....

Contact No.....

Date of Purchase

Model No.

Serial No.....

Gas Type

Installation Company.....

.....

.....

Engineer.....

Contact No.....

GasSafe Reg No.

Date of Installation

USER INSTRUCTIONS

GENERAL

Installation and servicing must only be carried out by a competent person whose name appears on the GasSafe register. To ensure the engineer is registered with GasSafe they should possess an ID Card carrying the following logo:



In all correspondence, please quote the appliance type and serial number, which can be found on the data badge.

Do not place curtains above the appliance: You must have 300mm clearance between the appliance and any curtains at either side.

No furnishings or other objects should be placed within 1 metre of the front of the appliance.

If a shelf is fitted, a distance of 300mm above the appliance opening is required.

If any cracks appear in the glass panel do not use the appliance until the panel has been replaced.

Do not obstruct the flue terminal in any way, i.e. by planting flowers, trees, shrubs etc. in the near vicinity, or by leaning objects against the terminal guard.

Do not put any objects on the terminal guard; it will lose its shape.

If you use a garden sprinkler, do not let quantities of water into the flue terminal.

This product is guaranteed for 5 years from the date of installation, as set out in the terms and conditions of sale between Gazco and your local Gazco retailer. Please consult with your local Gazco retailer if you have any questions. In all correspondence always quote the Model Number and Serial Number.

i **IMPORTANT: NEVER position a television or screen above this appliance.**

CO ALARMS

Building regulations require that whenever a new or replacement fixed gas burning appliance is installed in a dwelling, a carbon monoxide alarm complying with BS EN 50291-1 (latest edition) must be fitted in the same room as the appliance. Further guidance and recommendations on the installation of carbon monoxide alarms is available in BS EN 50292 (latest edition) and from manufacturers' instructions.

Provision of an alarm must not be considered a substitute for either installing the appliance correctly or ensuring regular servicing and maintenance of the appliance.

OPERATING THE APPLIANCE

There are 2 types of control systems available for this appliance:

1. Slide Control
2. Manual and Remote Control

Follow the relevant section for specific operation.

1. SLIDE CONTROL

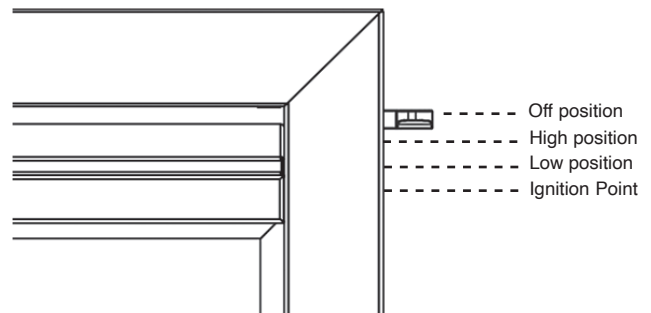
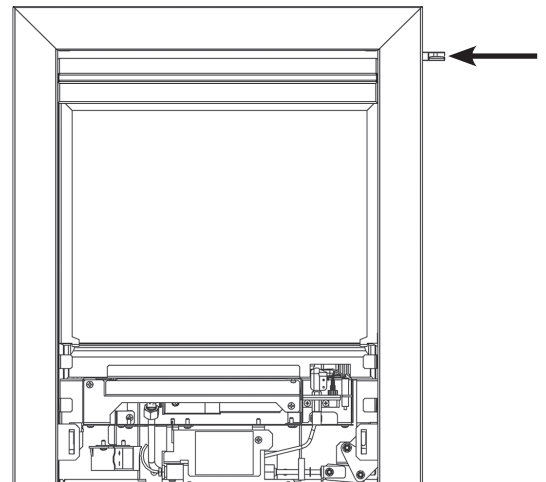

LIGHTING THE PILOT

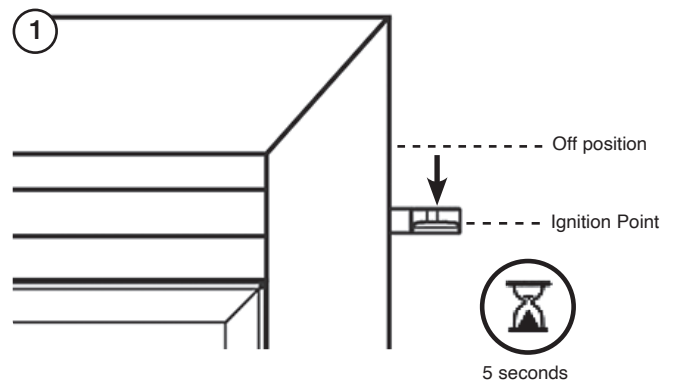

The appliance should light on its lowest setting. Repeat the above steps if the appliance does not light.

ADJUSTING THE FLAME HEIGHT

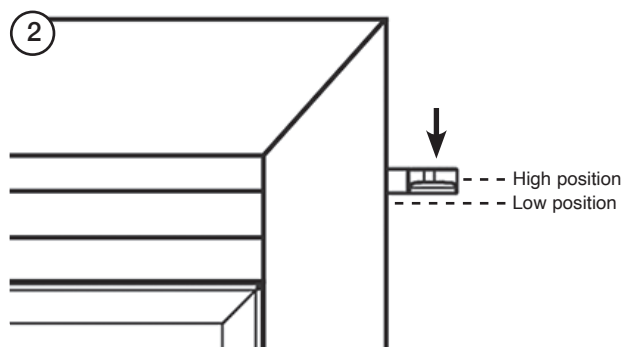
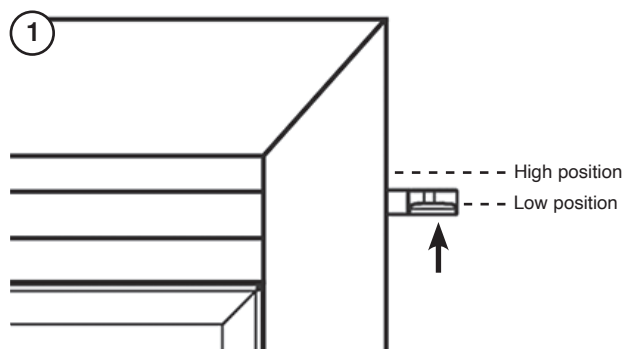

i **IMPORTANT: YELLOW FLAMES TYPICALLY APPEAR WHEN THE APPLIANCE HAS REACHED NORMAL OPERATING TEMPERATURE. THIS CAN TAKE UP TO 30 MINUTES.**

! **WARNING: IF THE APPLIANCE FAILS TO LIGHT OR BECOMES EXTINGUISHED IN USE, WAIT 3 MINUTES BEFORE ATTEMPTING TO RELIGHT.**

SWITCHING OFF THE APPLIANCE

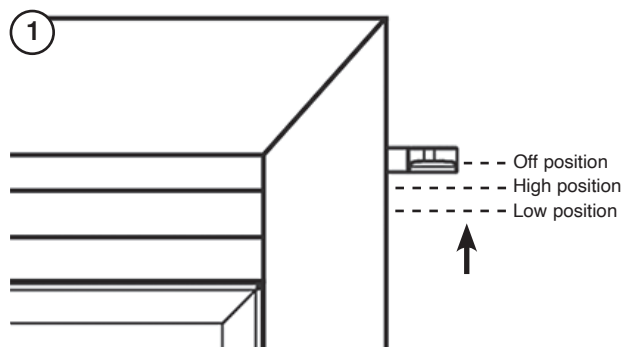

See Servicing to replace Slide Control.

2. MANUAL AND REMOTE CONTROL

There are two ways of lighting the appliance:

- a) Using the Manual Controls on the Control Box (located on the appliance).
- b) By thermostatic remote control.

2A. MANUAL OPERATION (CONTROL BOX)

The manual controls are located on the Control Box at the bottom of the appliance, behind the ash cover, see Diagram 1.

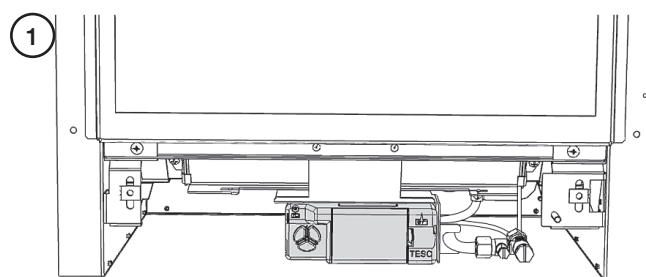

There are a series of buttons on the left hand side of the Control Box, see Diagram 2.

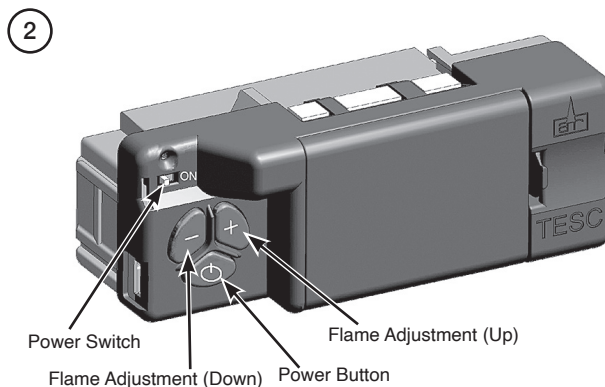

To operate the appliance the Power Switch on the Control Box must be switched ON.

i **Note: The Power Switch does not need to be turned off each time the appliance is not in use. However, if the appliance is left unattended for long periods of time (e.g. vacation), it is recommended to place the Power Switch into the off position.**

TURNING THE APPLIANCE ON

Press and hold the Power Button for 1 second and release. The burner will light within 2 seconds.

Use + and - buttons to adjust the flame height between Minimum and Maximum.

TURNING THE APPLIANCE OFF

Press the power button to turn the appliance off.

i **IMPORTANT: YELLOW FLAMES TYPICALLY APPEAR WHEN THE APPLIANCE HAS REACHED NORMAL OPERATING TEMPERATURE. THIS CAN TAKE UP TO 30 MINUTES.**

! **WARNING: IF THE APPLIANCE FAILS TO LIGHT OR BECOMES EXTINGUISHED IN USE, WAIT 3 MINUTES BEFORE ATTEMPTING TO RELIGHT.**

THE APPLIANCE MAY TAKE SEVERAL AUTOMATIC ATTEMPTS TO RESTART. DO NOT INTERRUPT THE VALVE DURING THIS PROCESS.

2B. REMOTE CONTROL

To operate the appliance the Power Switch on the Control Box must be switched ON (I), see left.

To activate the Remote Control it will be necessary to cradle the handset to unlock. The green light will illuminate to show the handset is ready to use.



i **IMPORTANT: Continue to cradle the handset throughout an operation to keep it unlocked. If the green light goes off during an operation it will be necessary to reposition the handset so the light comes back on and restart the operation.**

HANDSET FEATURES

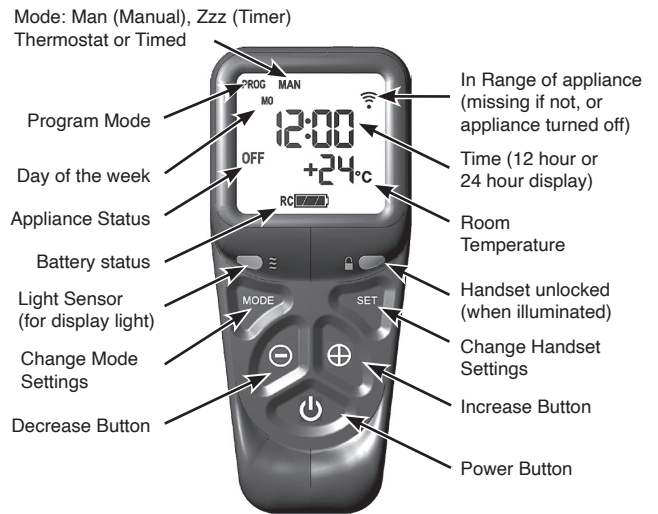

The Icon at the bottom of the screen displays the battery condition of both the batteries in the handset and in the Control Box alternatively.

RC = Remote Control Handset
FC = Fire Control (Control Box)

i **If the handset has been replaced or the fire serviced, it will need repairing, see Installation Section: Pairing the appliance – Remote Control Version Only.**

SETTING THE CLOCK

To adjust the time on the handset after initial set up:

Holding the remote to keep the green light on and the handset unlocked, press and hold the SET button until a beep is heard to indicate the command has been received.

Release the SET button. PROG will be displayed at the top left of the display.

Press the MODE button twice until SET UP flashes in the top right of the display.

Press and release the SET button. The handset will display H:24.



24 denotes a 24 hour clock and 12 denotes a 12 hour clock.

Press the + or - button on the handset to toggle between the two settings.

Press the SET button to confirm and progress to setting the day of the week.

SETTING THE DAY OF THE WEEK

Press and release the + and - buttons until the correct day of the week is shown on the display.



Mo = Monday, **Tu** = Tuesday, **We** = Wednesday, **Th** = Thursday, **Fr** = Friday, **Sa** = Saturday and **Su** = Sunday.

Press SET to confirm the day of the week and progress to setting the time.

SETTING THE HOUR

Press and release the + or - button to change the hour to the correct hour. Press SET to confirm and progress to setting the minute.

SETTING THE MINUTES

Repeat the process to change the minutes.

SETTING THE TEMPERATURE DISPLAY (CELSIUS OR FAHRENHEIT)

Press and release the + or - button to toggle between C and F. When the display shows the desired symbol, press and release the SET button to store.



To enter Advanced Settings, see Installation Instructions: Advanced Menu Settings.

To finish, place the handset down and wait until the home screen is displayed and the unlock light goes off.

! ALL THE NECESSARY SETTINGS REQUIRED HAVE NOW BEEN COMPLETED. ANY FURTHER FUNCTIONS ON THIS HANDSET ARE FOR FACTORY SETTING AND NOT TO BE USED.

The Handset is now ready to operate the appliance.

i If the handset has been replaced or the fire serviced, it will need repairing, see Installation Section: Pairing the appliance – Remote Control Version Only.

MANUAL OPERATION (REMOTE CONTROL)

To operate the appliance the Power Switch on the Control Box must be switched ON (I).





Power Switch

To activate the Remote Control it will be necessary to cradle the handset to unlock. The green light will illuminate to show the handset is ready to use.



i IMPORTANT: Continue to cradle the handset throughout an operation to keep it unlocked. If the green light goes off during an operation it will be necessary to reposition the handset so the light comes back on and restart the operation.

TURNING THE APPLIANCE ON

Press the  Power Button until Pilot flashes on the display. Release the  Power Button and the Flame symbol will appear on the display.

If the button is held the command will be cancelled for safety reasons.

Holding the handset to unlock, use + and - buttons to adjust the flame height between Minimum and Maximum.

TURNING THE APPLIANCE OFF

Holding the handset to unlock, press the  power button to turn the appliance off.



IMPORTANT: YELLOW FLAMES TYPICALLY APPEAR WHEN THE APPLIANCE HAS REACHED NORMAL OPERATING TEMPERATURE. THIS CAN TAKE UP TO 30 MINUTES.



WARNING: IF THE APPLIANCE FAILS TO LIGHT OR BECOMES EXTINGUISHED IN USE, WAIT 3 MINUTES BEFORE ATTEMPTING TO RELIGHT.

THE APPLIANCE WILL TAKE 3 AUTOMATIC ATTEMPTS TO RESTART. DO NOT INTERRUPT THE VALVE DURING THIS PROCESS.

SETTING TIMER MODE (IN MANUAL OPERATION)

Timer Mode will turn the appliance off after a set period of time has elapsed.

Timer Mode can be set before or during manual operation of the fire.

Hold the handset to unlock, and press and release the MODE button.

The word MAN and the Zzz symbols flash at the top of the display.

Press and release the SET button. This will activate the Timer mode.

The default time period is 1 hour.

To increase the time period, pressing the SET button again will show the remaining time.

This can be altered by pressing the + or - buttons.

The timer can be set between 1 minute and 24 hours.

After adjusting the time, press SET again to confirm the time setting desired.

Once the countdown has reached zero the fire will turn off.



NOTE: If Timer mode is activated and the fire is manually turned off, the timer will be cancelled. Changes to the Timer will reset to the default time on next use.

If the fire is off when the Timer mode is set then the timer will automatically start when the fire is turned on.

THERMOSTATIC MODE

The handset contains a thermostatic sensor to control the operation of the appliance according to the temperature of the room.

There are 3 temperature options that can be set:

Day Mode - indicated by a Sun symbol on the display (default temperature 24°C)

Night Mode - indicated by a Moon symbol on the display (default temperature 18°C)

Frost Protection - indicated by a Snowflake symbol on the display (default temperature 5°C)

PROGRAMMING THE MODES

Holding the handset to unlock, press and hold the SET button until a beep is heard to indicate the command has been received.

Release the SET button.

PROG and a flashing thermometer symbol will be displayed at the top of the display.

Press and release the SET button to enter Day Mode.

To change the temperature press + or - whilst the set temperature is displayed to alter the setting.

Press and release the SET button to confirm and to scroll to the Night Mode.

To change the temperature press + or - whilst the set temperature is displayed to alter the setting.

Press and release the SET button to confirm and to scroll to Frost Protection Mode.

To change the temperature press + or - whilst the set temperature is displayed to alter the setting.

When finished press the SET button again and the new settings will be accepted.

The display will return to the time of day screen.

CHANGING TEMP IN A MODE

When choosing a mode during operation the temperature can be temporarily changed; however these settings will reset to the previously set programmed settings when the fire is turned off.

Holding the handset to unlock, press the SET button.

With the temperature displayed, press + or - to alter the setting.

When finished press SET again and the new setting will be accepted.

The display will return to the time-of-day screen.

The handset must be left in the chosen mode for it to operate.

If at any time the power button is operated during Thermostatic Mode the control will cancel any thermostat operation and return the handset to Manual Mode.

SETTING TIMER MODE (IN THERMOSTATIC OPERATION)

Timer Mode will turn the appliance off after a set period of time has elapsed.

Timer Mode can be set before or during thermostatic operation of the fire.

Hold the handset to unlock, press and release the MODE button until the word MAN and the Zzz symbols are flashing at the top of the display.

Press and release the SET button. This will activate the Timer mode.

The default time period is 1 hour.

To increase the time period, pressing the SET button again will show the remaining Time. This can be altered by pressing the + or - buttons.

The timer can be set between 1 minute and 24 hours.

After adjusting the time press SET again to confirm the time setting desired.



Once the countdown has reached zero the fire will turn off.

i **NOTE: If Timer mode is activated and the fire is manually turned off, the timer will be cancelled. Changes to the Timer will reset to the default time on next use.**

If the fire is off when the Timer mode is set then the timer will automatically start when the fire is turned on.

OPERATING THE APPLIANCE

TURNING THE APPLIANCE ON

Press the  Power Button until Pilot flashes on the display. Release the  Power Button and the Flame symbol will appear on the display.

If the button is held the command will be cancelled for safety reasons.

Holding the handset to unlock, use + and - buttons to adjust the flame height between Minimum and Maximum.



TURNING THE APPLIANCE OFF

Holding the handset to unlock, press the power button to turn the appliance off.

i **IMPORTANT: YELLOW FLAMES TYPICALLY APPEAR WHEN THE APPLIANCE HAS REACHED NORMAL OPERATING TEMPERATURE. THIS CAN TAKE UP TO 30 MINUTES.**

! WARNING: IF THE APPLIANCE FAILS TO LIGHT OR BECOMES EXTINGUISHED IN USE, WAIT 3 MINUTES BEFORE ATTEMPTING TO RELIGHT.

THE APPLIANCE WILL TAKE 3 AUTOMATIC ATTEMPTS TO RESTART. DO NOT INTERRUPT THE VALVE DURING THIS PROCESS.

PAGING THE HANDSET

If the handset is lost it can be located by pressing the + only on the Control Box for 5 seconds.

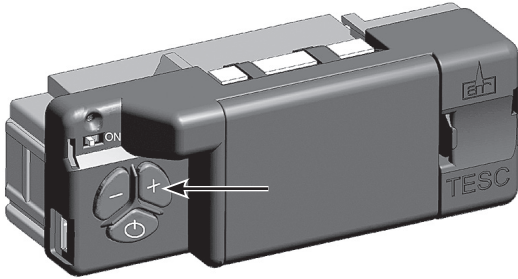

The handset will flash and make a noise for 60 seconds to indicate where it is. Pick up the Handset and cradle it to unlock. The flashing and noise will stop.

If the handset is not discovered in 60 seconds the process will need to be repeated.

i If the handset has been replaced or the fire serviced, it will need repairing, see Installation Section: Pairing the appliance — Remote Control Version Only.

CHECKING IF HANDSET NEEDS REPAIRING

Stand a meter from the appliance. Pick up the Handset and cradle it to unlock.



If there is no symbol in the top right corner of the home screen or the error message below is showing, the handset needs repairing.



SUPPORT VIDEOS

For help with pairing and using your TESCR5 valve and remote control, please scan the QR code or visit Stovax.com.



TROUBLESHOOTING: HANDSET

ERROR CODE	MEANING	POSSIBLE REASONS
E00	Occurs after attempting (but failing) to light after all automatic (re)start cycle(s).	No gas at all to pilot or main burner.
		Pilot pipe from valve to pilot blocked.
		Pilot injector blocked. Pilot head damaged or contaminated.
		Loose burner medium/ember glow contaminating pilot area.
		Pilot aeration hole blocked by lint.
		No spark at electrode, tracking out somewhere.
		Thermocouple is aged or damaged and is not producing enough output.
		The insulation on the thermocouple wire is damaged causing short to chassis metal.
E01	Occurs when there has been a good electronic flame signal and the temperature of the thermocouple was once hot enough, but then it became cooler.	Possibly the content of CO is too high in ambient atmosphere.
		Problems with chimney or room air inlets (insufficient air circulation).
		Incorrect balanced flue pipe configuration or incorrect flue restrictor fitted.
		Unstable pilot flame (i.e. wind, insufficient thermocouple couple position).
		Contaminated pilot, giving poor flame that heats thermocouple.
		Intermittent failure in Thermocouple (only when hot). Inner wire in head maybe making contact when cold but not when hot.
E02	Ambient temperature around Gas valve in the fire too hot (exceeded 72°C).	Faulty installation of fire (not sealed in correctly in fire opening).
		Problems with chimney (insufficient air circulation).
		Incorrect enclosure ventilation on balanced flue.
E03	Thermocouple connection to valve issue. Incorrect reading from thermocouple.	No Thermocouple connected.
		Thermocouple connection reversed / connected incorrectly.
		Insulated thermocouple wire shorting to chassis earth (damaged insulation).
		Damaged or defective, worn-out thermocouple.
E04	Flame detected on pilot after valve has shutdown.	Carbon or soapy/conductive contamination on spark electrode.
		Combustible material burning on pilot near electrode (Carbon deposits etc).
E05	Flame detected on pilot before valve has started.	Carbon or soapy/conductive contamination on spark electrode.
		Combustible material burning on pilot near electrode (Carbon deposits etc),
E06 & E07	Occurs when supply voltage is too low to operate the valve.	Batteries are completely flat (may display random error codes in this case, not just E06 and E07).
		Damaged battery contacts (dirty, corroded, bent so not making strong contact with batteries).
		Short circuit in external wiring (Battery box).
		Defective USB power supply (if used) or damaged wiring to it.
		Contact problem of slide switch (moving on/off, on/off several times may clean contacts).
		Batteries not in correct way around.
E24	Occurs when thermocouple does not reach its final temperature within 1 minute.	Aged thermocouple.
		Thermocouple wire insulation damage and shorting to metal chassis.
		Problems with chimney or room air inlets (insufficient air circulation).
		Unstable pilot flame (i.e. wind, insufficient thermocouple couple position).
		Contaminated pilot, giving poor flame that heat thermocouple (see section on pilot).
E48	Occurs when the control detects a short circuit of the couple.	Poor position of Ceramic parts (i.e. coals, logs or matrix).
		Thermocouple connection reversed / connected incorrectly.
		Insulated thermocouple wire shorting to chassis earth (damaged insulation).
		Damaged or defective, worn-out thermocouple.
		Weak connection of thermocouple to valve.

REPLACING THE APPLIANCE BATTERIES

Replace batteries at least every 12 months during the annual service of the fire.

i It is essential to use high quality batteries (Duracell or equivalent) when replacing batteries.

REMOTE CONTROL

The icon at the bottom shows the battery condition of both the batteries in the handset and in the Control Box alternately, see Diagram 1.



RC = Remote Control Handset
FC = Fire Control (Control Box)

i Note: Change the batteries in the handset before they are flat, to avoid having to reprogram the time of day in again. N.B. Pairing is not lost, even if the batteries are removed or flat.

The appliance Control Box requires 3 AA size alkaline batteries.

The handset requires 2 AA size alkaline batteries.

The appliance battery is located in the Control Box at the bottom of the appliance behind the ash cover.

Slide the Power Switch on the Control Box to the OFF position before attempting to change the batteries.

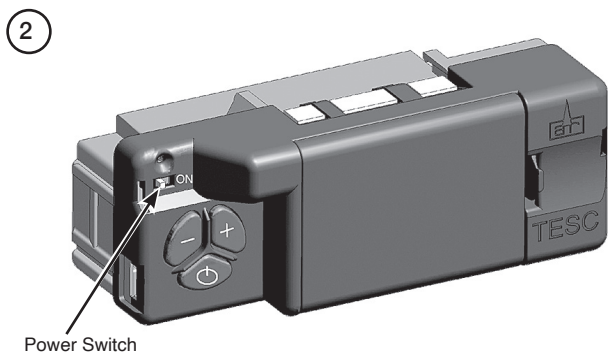

The battery covers can be opened without tools by using a fingernail and pressing to unhook the clip that retains the cover, see Diagram 3.

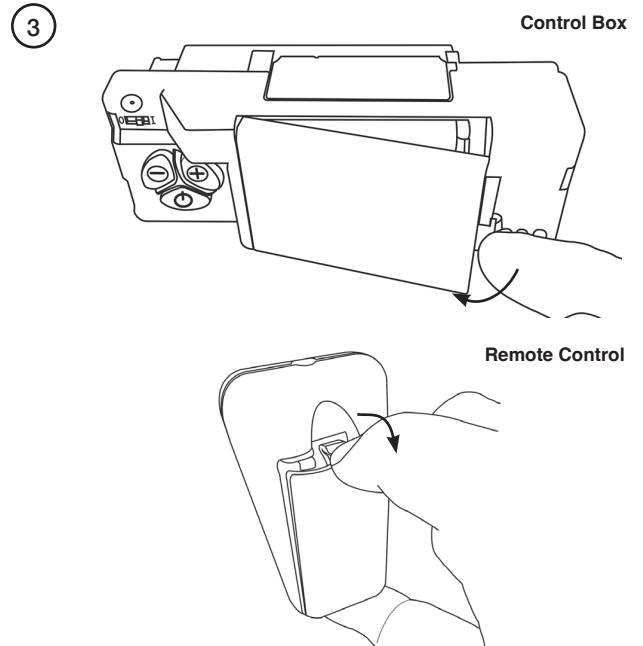

The orientation of these is shown molded into the battery compartment, see Diagram 4.

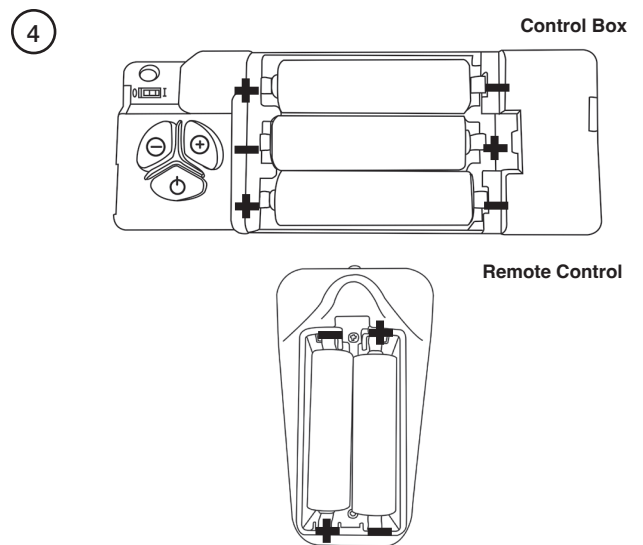

i Power Supply via Micro USB

It is possible to power the Control Box via a 5V Micro USB connection, see Diagram 5. If a USB lead is used batteries are not required in the Control Box.

DO NOT CONNECT OTHER ELECTRIC DEVICES TO THE CONTROL BOX.

After fitting the batteries, slide the Power Switch on the Control Box to the ON position for the appliance to operate, see Diagram 5.

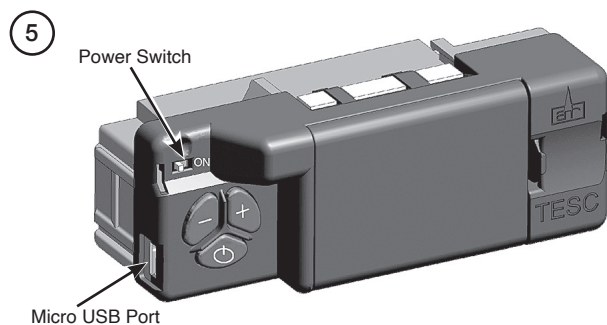

i **Note: The Power Switch does not need to be turned off each time the appliance is not in use. However, if the appliance is left unattended for long periods of time (e.g. vacation), it is recommended to place the Power Switch into the off position.**

SLIDE CONTROL

The battery box is located at the bottom left of the appliance behind the ash cover.

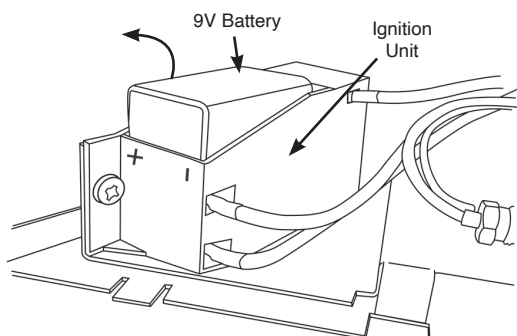

Remove the old battery and replace with a new high quality (Duracell or similar) 9V battery.

CLEANING THE APPLIANCE

Make sure the appliance and surrounds are cool before trying to clean.

Refer to the separate decorative front instructions to remove the front from the appliance.

Remove the glass frame by removing the 4 screws in the retaining bracket, see Diagram 1.

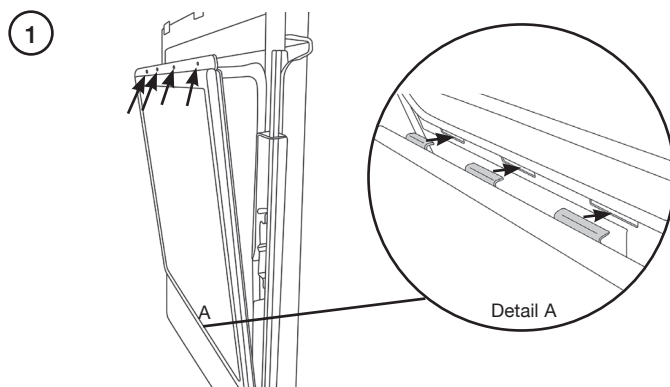

Tilt the top of the glass frame forward and disengage the lower location tabs from the slots in the firebox, see Diagram 1, Detail A. Place carefully to one side.

To clean the glass surface, Gazco recommends you use hot soapy water.

The glass frame must be refitted to the appliance following cleaning or servicing. Ensure that the rope seal on the box is intact, then locate the glass frame location tabs into the slots on the firebox, see Diagram 1, Detail A.

Secure the glass frame using 4 screws in the retaining bracket, see Diagram 1.

Replace ALL of the securing screws ensuring that a screw is present in all fixing slots.

NEVER OPERATE THE APPLIANCE WHEN THE GLASS FRAME IS REMOVED OR BROKEN.

Refer to the separate decorative front instructions to replace the front on the appliance.

! UNDER NO CIRCUMSTANCES SHOULD THE APPLIANCE BE USED IF ANY OF THE GLASS FRAME RETAINING SCREWS ARE LOOSE OR MISSING.

ARRANGEMENT OF THE FUEL BED

ADVICE ON HANDLING AND DISPOSAL OF FIRE CERAMICS



BLACK REED LINERS

These lining panel options are available for this product and contains Refractory Ceramic Fibre (RCF), a material which is commonly used for this application.

RCF waste is classed as stable, non-reactive hazardous waste and may be disposed of at a licensed landfill site.

If replacing these items, do not break them up. Seal within heavy duty polythene bags and label as RCF waste.

Protective clothing is not required when handling these articles.

If the Liners are visibly broken Gazco recommend using gloves and a face mask to remove the pieces and remove any dust accumulated in and around the appliance before and after working on it with a HEPA filtered vacuum.

If any concerns remain contact Gazco Technical Customer Services to obtain the manufacturers COSHH Date Sheet.

LOG LAYOUT

LOGS MUST BE POSITIONED ACCORDING TO THE FOLLOWING INSTRUCTIONS TO GIVE THE CORRECT FLAME EFFECT.

Ensure the burner tray is clean and free from any debris, see Diagram 1.

Note: The LPG and Nat Gas burner trays are visually different but the log layouts are the same.

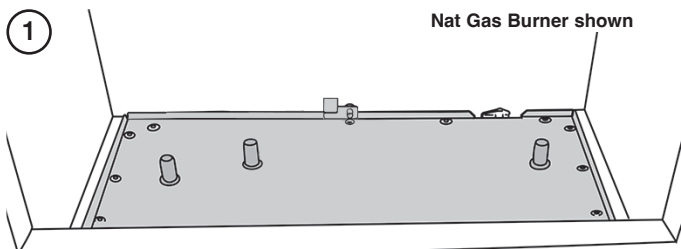

Place Log A in position on the 2 locating pins, see Diagram 2.

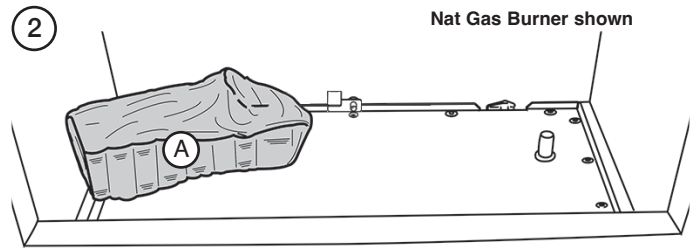

Spread the Lava Rock evenly over the fuel bed and around Log A, see Diagram 3.

Ensure that the fuel effect does not obstruct the pilot.

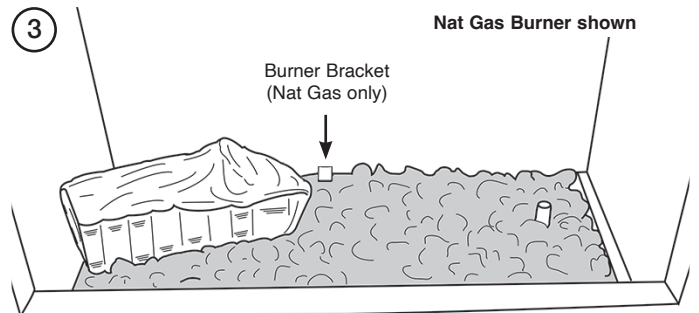

Log B is positioned on the right hand locating pin, and rests against the back liner, see Diagram 4.

Nat Gas only - ensure that the left hand side rests on the burner bracket, see Diagrams 3 & 4.

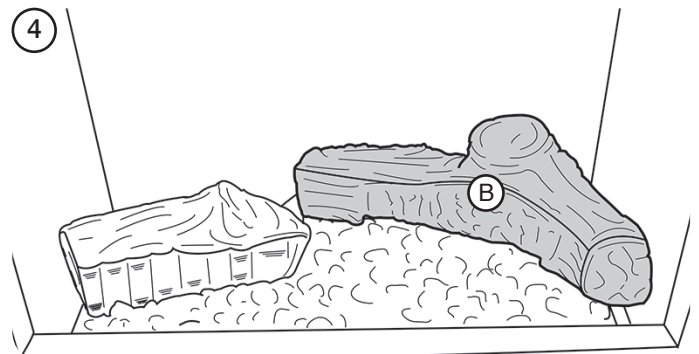

Log C rests on Log A and the front tray with the locating pin facing up, see Diagram 5.

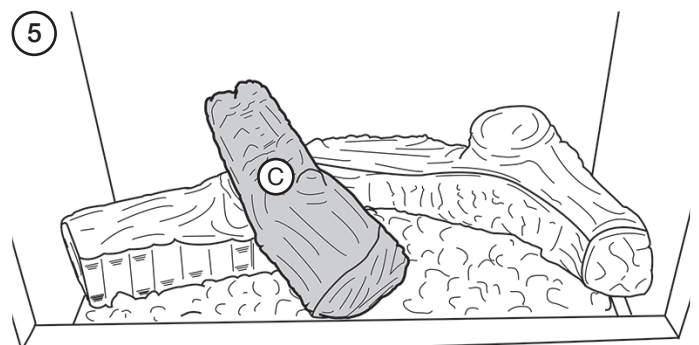

Log D fits onto the locating pin and rests on Log B, see Diagram 6.

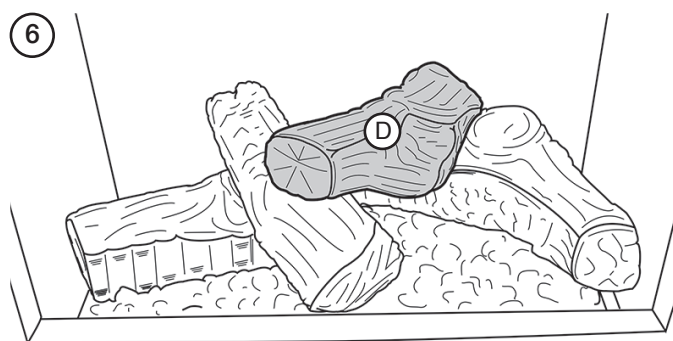

Position the 2 embers in the front right and back left corners, see Diagram 7.

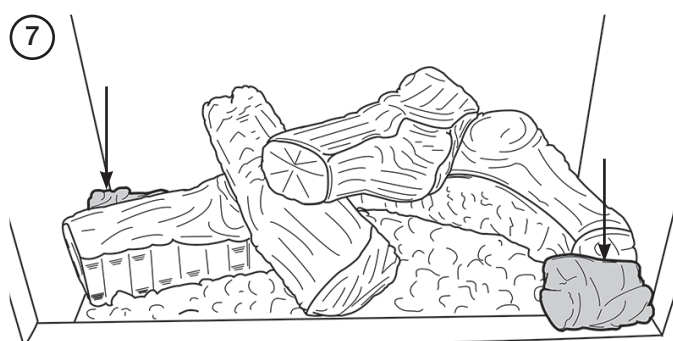

Sparsingly spread an amount of the Embaglow fibres provided on the sections highlighted, see Diagram 8.

Take care not to use more than half a packet per application.

WARNING - DO NOT PLACE NEAR THE PILOT AREA.

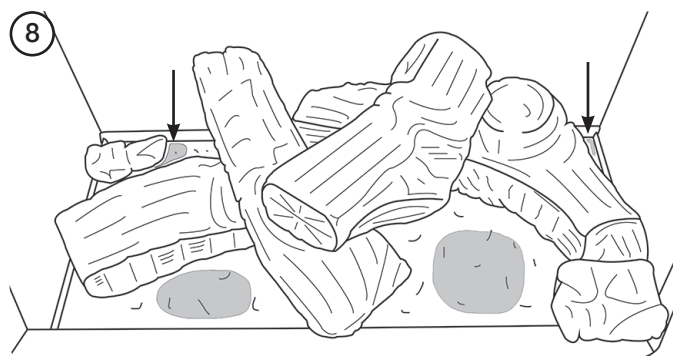

FLAME FAILURE DEVICE

This is a safety feature incorporated on this appliance which automatically switches off the gas supply if the pilot goes out and fails to heat the thermocouple.

Remote Only: In the event of flame extinction the control will make several attempts to restart. DO NOT interrupt the valve during this process.

IF THIS OCCURS DO NOT ATTEMPT TO RELIGHT THE APPLIANCE FOR 3 MINUTES.

RUNNING IN

During initial use of a new GAZCO appliance a strong odour will be encountered as various surface coatings become hot for the first time. Although these odours are harmless it is recommended that the appliance is operated on maximum for 4 to 8 hours in order to fully burn off these coatings. After this period the odours should then disappear.

If the odours persists, please contact your installer for advice.

During the first few hours of burning there may be discolouration of the flames. This will also disappear after a short period of use.

SERVICING

The appliance must be serviced every 12 months by a qualified GasSafe Engineer. In all correspondence always quote the Model number and the Serial number which may be found on the Commissioning Checklist (Page 3).

VENTILATION

Any purpose provided ventilation should be checked periodically to ensure that it is free from obstruction.

INSTALLATION DETAILS

Your installer should have completed the commissioning sheet at the front of this book. This records the essential installation details of the appliance. In all correspondence always quote the Model number and Serial number.

HOT SURFACES

Parts of this appliance become hot during normal use.

Regard all parts of the appliance as a working surface, except for the control access panel and the slider handle (slide control model only).

Provide a suitable fireguard to protect young children and the infirm.

SERVICING AND SUPPORT



To keep your appliance looking and performing at its best, it must be serviced annually. This service must be undertaken by a suitably qualified individual and your retailer can organise this for you.

Alternatively, Gazco offer a manufacturers premium service with our friendly team of qualified engineers which can be booked at www.gazco.com/support.

In all correspondence always quote the Model number and the Serial number which may be found on the Commissioning Checklist (Page 3).

INSTALLATION INSTRUCTIONS

TECHNICAL SPECIFICATION

Covering the following models:

GAS TYPE	LOGIC HE BF	
	REMOTE CONTROL	SLIDE CONTROL
Nat Gas	101-014	101-281
LPG	101-666	101-516

MODEL	APP CAT.	GAS TYPE	WORKING PRESSURE	AERATION	INJECTOR	GAS RATE M ³ /H	INPUT KW (GROSS)		COUNTRY
							HIGH	LOW	
Logic HE BF Log Remote	I ₂ H	Natural Gas G20	20mbar	2 x 4mm	161	0.400	4.2	2.5	GB, IE
	I ₃ P	Propane G31	37mbar	2 x 12mm	104	0.154	4.1	2.5	GB, IE
Logic HE BF Log Slide	I ₂ H	Natural Gas G20	20mbar	2 x 4mm	161	0.419	4.3	2.6	GB, IE
	I ₃ P	Propane G31	37mbar	2 x 12mm	104	0.158	4.2	2.6	GB, IE
Efficiency 86% Net (Class 1)									
NOx Class 4									
Flue Outlet Size Ø 100mm									
Flue Inlet Size Ø 152mm									
Gas Inlet Connection Size Ø 8mm									



The net efficiency of this appliance has been measured as specified in EN613:2001 and the result after conversion to gross using the appropriate factor from Table E4 of SAP 10.2 is 79.9%. The test data has been certified by Kiwa Nederland BV. The gross efficiency value may be used in the UK Government's Standard Assessment Procedure (SAP) for energy rating of dwellings.

PACKING CHECKLIST

QTY DESCRIPTION	FIXING KIT CONTAINING:
Log Version 1 x Log Set 1 x Lava Rock	1 x Instruction Manual 1 x Embaglow 1 x 1.7m Silicone Seal 4 x Wall Plugs 4 x Wood Screws 1 x 9V Battery (Slide Only) 5 x AA Battery (Remote Only)

TECHNICAL SPECIFICATION

COMPLETE FRONT OPTIONS

FRONT	MANUAL & REMOTE	SLIDE CONTROL
Designio2	901-493, 901-526	901-539, 901-643
Tempo	912-197, 912-221, 912-316	901-385, 901-403, 901-414
Winchester	8697MB	901-369
Vogue	901-440	
Beat	901-350	
Stockton	901-488	
Dartmouth	YM989-001	

FRAME & FRONT COMBINATIONS

FRAMES		
	BOX PROFIL2 FRAME *	
FINISH	MANUAL & REMOTE	SLIDE
Matt Black	912-232	901-272
Polished Brass Effect	912-140	901-286
Polished Steel Effect	912-027	901-299
Brushed Steel Effect	912-358	901-310

FRONTS			
FINISH	ARTS FRONT	WAVE FRONT	CHARTWELL FRONT
Matt Black	901-425	901-024	901-159
Polished Brass Effect	901-530	901-061	901-164
Highlight Polished	901-296	901-092	901-185
Polished Chrome	901-476	901-083	901-170

* A Box Profil2 Frame must be used in conjunction with an Arts, Wave or Chartwell Front.

TECHNICAL SPECIFICATION

OVERALL EXTERNAL DIMENSIONS

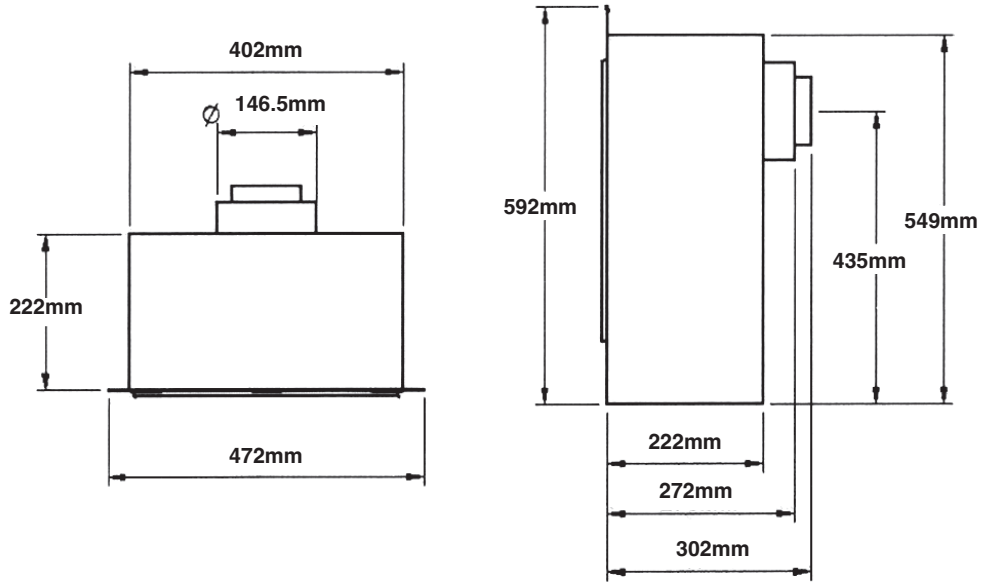

MINIMUM AND MAXIMUM FLUE SIZE

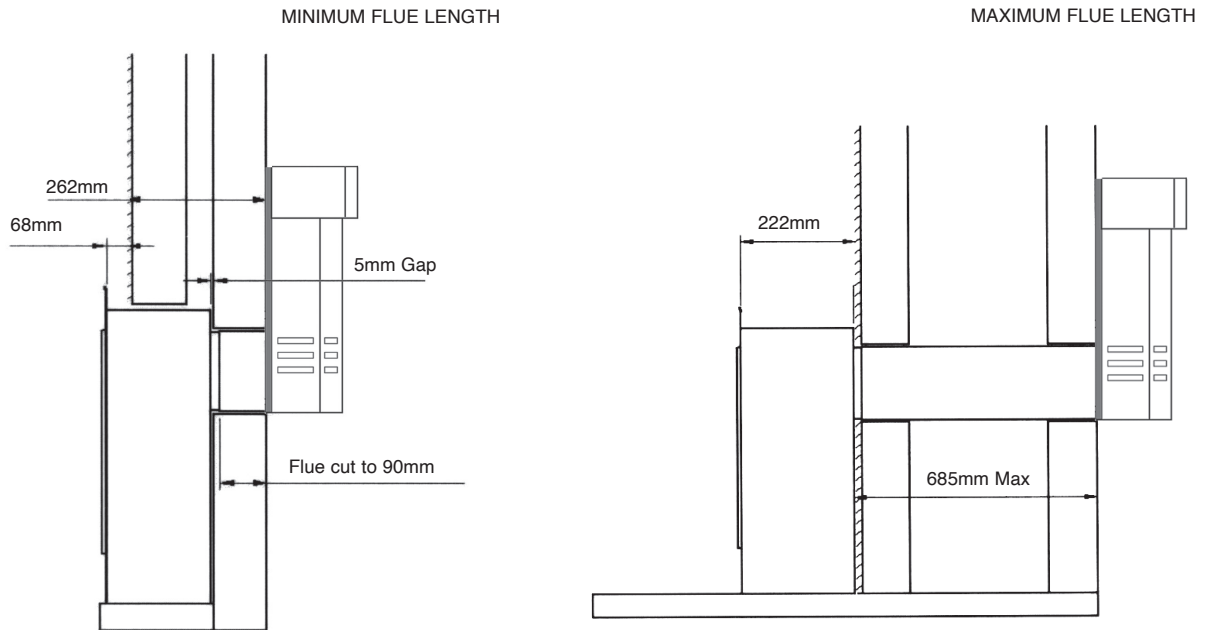

SITE REQUIREMENTS

FLUE & CHIMNEY REQUIREMENTS

NOTE: This appliance can only be installed in conjunction with the flue supplied.

You must adhere to the following:

The flue must be sited in accordance with BS5440: Part 1 (latest edition), see below.

Fit a guard to protect people from any terminal less than 2 metres above any access such as level ground, a balcony or above a flat roof.

The flue must be securely fixed and fire precautions followed in accordance with local and national codes of practice.

The horizontal terminal can be reduced in length, see Page 20.

UK Dimensions

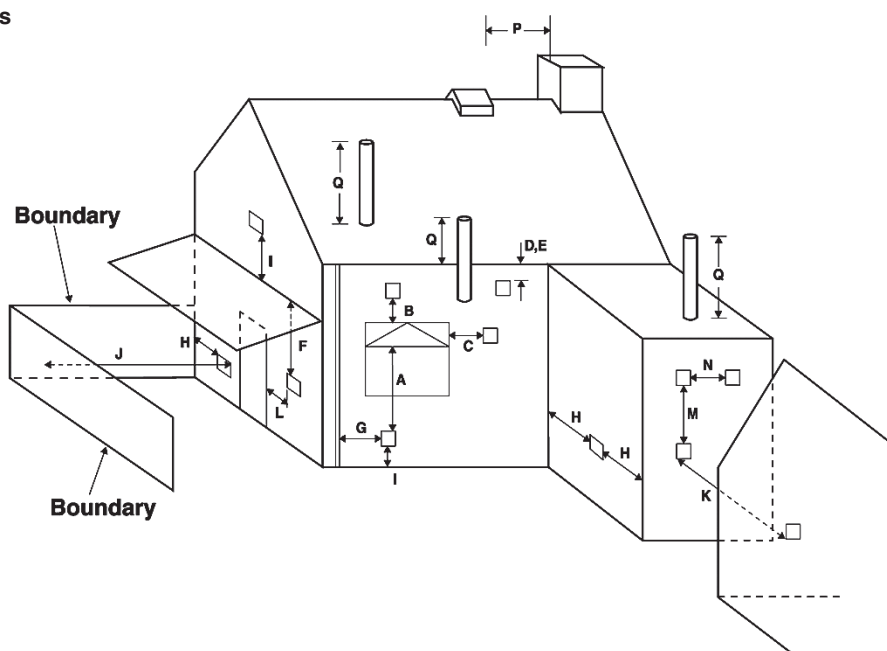

DIMENSION	TERMINAL POSITION	MINIMUM DISTANCE
A*	Directly below an opening	600mm
B*	Above an opening	300mm
C*	Horizontally next to an opening	400mm
D	Below gutters, soil pipes or drain pipe	300mm
E	Below eaves	300mm
F	Below balcony or car port roof	600mm
G	From a vertical drain pipe or soil pipe	300mm
H	From an internal or external corner or to a boundary alongside the terminal	600mm
I	Above ground, roof or balcony level	300mm

DIMENSION	TERMINAL POSITION	MINIMUM DISTANCE
J	From a surface or boundary facing the terminal	600mm
K	From a terminal facing the terminal	600mm
L	From an opening in the car port (e.g. door, window) into the dwelling	1200mm
M	Vertically from a terminal on the same wall	1200mm
N	Horizontally from a terminal on the same wall	300mm
P	From a structure on the roof	600mm
Q	Above the highest point of intersection with the roof	300mm

* In addition, the terminal should not be nearer than 300mm to an opening in the building fabric formed for the purpose of accommodating a built-in element such as a window frame.

SITE REQUIREMENTS

REAR FLUE

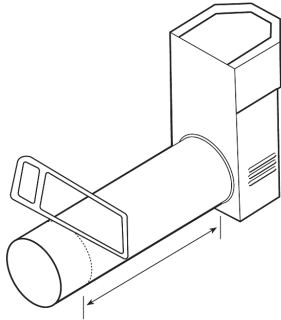

Terminal dimensions:
395 x 200 x 200mm (H x W x D)
Guard supplied
Cut to length as required on site.

Decide on the terminal position.

Measure the height from the finished hearth level/ base of the appliance to the centre of the required hole.

A masonry installation requires the addition of a suitable lintel to support the opening. Refer to Installation Instructions, Technical Information for details of the flue length.

NOTE - Carefully consider:

- a) Terminal positions
- b) Flue supports
- c) Weatherproofing
- d) Fire precautions

For all the above options, you must conform to local and national codes of practice.

Use only Gazco supplied flue on this appliance.

A guard (supplied) must be fitted to any terminal less than 2 metres above any access such as level ground, a balcony or above a flat roof.

TIMBER FRAMED BUILDINGS

It will be necessary to provide additional clearance when the flue passes through a wall containing any combustible materials so as to prevent a fire hazard.

The hole through which the flue will pass, must have a steel sleeve which is positioned so that an air gap of at least 25mm is maintained between the outer surface of the flue, and any part of the sleeve.

For further guidance on the installation of gas appliances in timber framed buildings, contact your local buildings control authority.

GAS SUPPLY

Before installation, ensure that the local distribution conditions (identification of the type of gas and pressure) and the adjustment of the appliance are compatible.

Ensure the gas supply delivers the required amount of gas and is in accordance with the rules in force.

Factory-sheathed/wrapped soft copper tubing with small ridges which allow pipe movement are considered to be a suitable alternative to a pipe sleeve, when recessing the unit into a cavity wall the gas supply is best fed through the wall from the outside. Soft soldered joints can only be used outside the appliance.

This appliance is supplied complete with a factory fitted isolation device incorporated into the inlet connection. No further isolation device is therefore required.

VENTILATION

This appliance requires no additional ventilation.

SITE REQUIREMENTS

APPLIANCE LOCATION

NOTE: It is recommended you construct the back panel of the fireplace from natural materials cut into three or more sections to prevent cracking. Resin-based materials may not be suitable. This appliance is an effective heat producer and attention must be paid to the construction and finish of the fireplace.

This appliance must stand on a non-combustible hearth that is at least 12mm thick.

It must be fitted into a non-combustible opening. The minimum dimensions shall be as shown below.

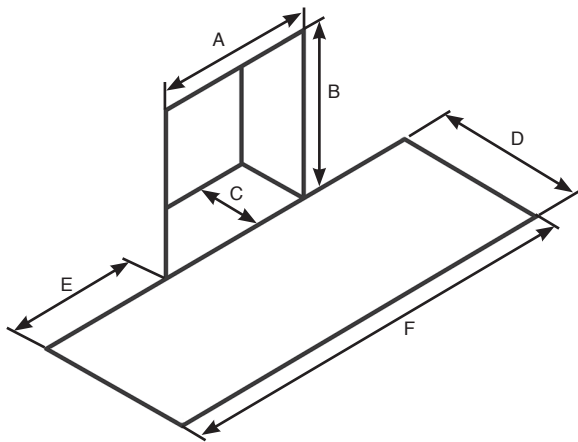

DIMENSIONS	MIN	MAX
A	420mm	450mm
B	560mm	575mm
C	230mm	-
D	300mm	-
E	150mm	-
F	720mm	750mm

These appliances must be hearth mounted into a fireplace opening conforming to National Standards.

If the appliance is greater than 50mm above the floor, then no hearth is required, although due consideration should be given to how the heat may affect the floor material.

This appliance can only be installed on an outside wall with suitable clearances for the flue terminal and guard (if required).

This appliance is not suitable for installation into a combustible wall. All combustible material must be removed from the area shown, see below.

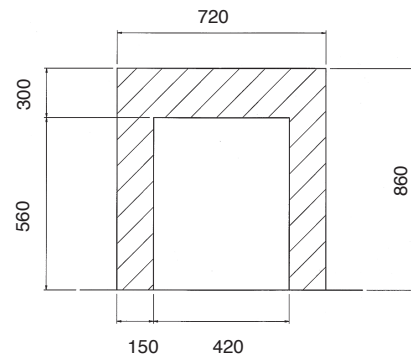

The maximum depth of combustible shelf is 150mm at a minimum height of 300mm above the fireplace opening.

INSTALLATION INSTRUCTIONS

SAFETY PRECAUTIONS

For your own and other's safety, you must install this appliance according to local and national codes of practice. Failure to install the appliance correctly could lead to prosecution. Read these instructions before installing and using this appliance.

These instructions must be left intact with the user.

Do not attempt to burn rubbish on this appliance.

Keep all plastic bags away from young children.

Do not place any object on or near to the appliance and allow adequate clearance above the appliance.

IF THE APPLIANCE IS EXTINGUISHED OR GOES OUT IN USE, WAIT 3 MINUTES BEFORE ATTEMPTING TO RELIGHT THE APPLIANCE.



IMPORTANT: REFER TO DATA BADGE AND TECHNICAL SPECIFICATION AT THE FRONT OF THE MANUAL TO ENSURE THE APPLIANCE IS CORRECTLY ADJUSTED FOR THE GAS TYPE AND CATEGORY APPLICABLE IN THE COUNTRY OF USE.

UNPACKING

Remove the appliance from its packaging, and check that it is complete and undamaged.

Put the loose ceramic parts to one side so that they are not damaged during installation.

INSTALLATION OF THE GAS SUPPLY

For specific gas types and working pressures see Technical Specification, Page 16.

Before installation, ensure that the local distribution conditions (identification of the type of gas and pressure) and the adjustment of the appliance are compatible. See Technical Specification on Page 16.

The position of the gas inlet pipe is shown, see Diagram 1.

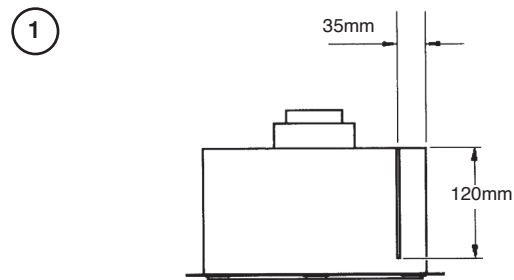

All supply pipes must be purged of any debris that may have entered, prior to connection to the appliance.

The gas supply enters through the silicone panel located on the rear of the outer box. This will need to be slit with a sharp knife prior to passing the supply pipe through.

PREPARING THE APPLIANCE

Remove the backing from the self-adhesive silicone sealing strip and apply to the rear flange of the firebox ensuring that the strip is positioned as close to the outer edge as is practically possible, see Diagram 1, Arrow A.

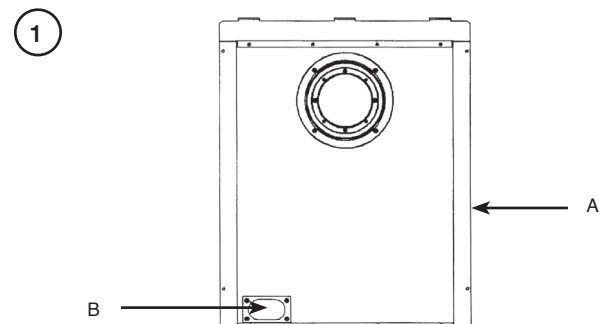

Gas pipe entry must come through the rear right-hand side of the box. The rubber seal must be cut using a sharp knife to allow the isolating elbow to pass through it. Ensure the rubber is not damaged when doing this, see Diagram 1, Arrow B.

A means of isolation is provided with the appliance. This must be fitted to the supply pipe prior to installing the firebox.

The appliance can either be recessed into an inner leaf of the wall. A 75mm rebated surround must be used with this method. Or it can be installed in front of the wall in conjunction with a fire surround

constructed of a studwork frame, Diagrams 2a & 2b for options. **If using a back panel constructed from natural materials such as stone, the panel should consist of 3 or more sections to reduce the risk of cracking.**

2a

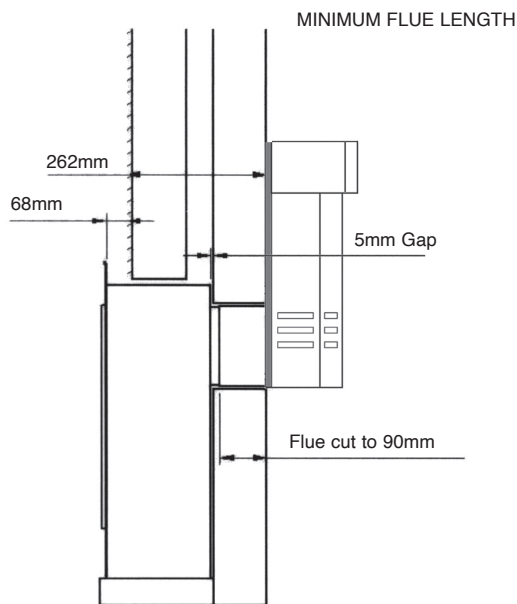

2b

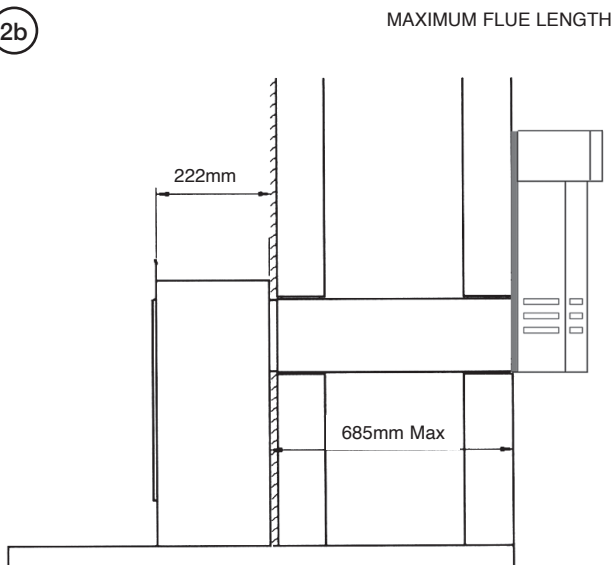

NON-RECESSED INSTALLATION

Mark the position of the flue on the inner wall by measuring from the top of the finished hearth level.

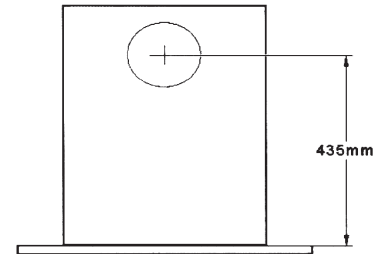

A 152mm (6") diameter hole is required to install the flue. This can be achieved by either:

- Core drill
- Hammer and chisel.

It is advisable to drill small holes around the circumference when using method b. Make good both ends of the hole.

It will now be necessary to construct a studwork frame to house the appliance. The minimum depth of the aperture must be 230mm. This includes an air gap of 5mm behind the appliance. The sides must be lined with non-combustible material for the full depth of the aperture.

Combustible parts of the studwork frame must not be any closer than the minimum dimensions shown below. These dimensions need to be maintained even if the frame work is protected by non-combustible material.

Do not pack the void around or above the appliance with insulation material such as mineral wool.

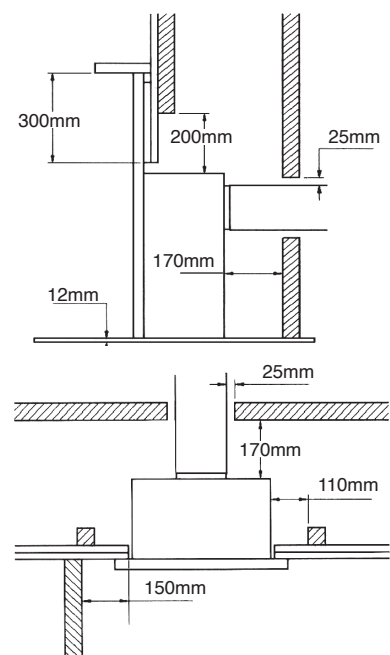

The void into which the appliance is fitted must be ventilated to prevent a build up of heat and to ensure pressure relief in the event of delayed ignition. If the void is sealed then it will be necessary to fit vents at both low and high levels with a minimum open free area of 50cm² each. These vents should take cold air from the room and return warm air back into the room.

RECESSED INSTALLATION

This method of installation requires structural alteration to the intended location. A suitable supporting lintel must be installed to maintain the structural integrity of the surrounding blockwork.

Mark the position of the lintel so that it sits centrally over the intended installation. Remove the blockwork and install the lintel using mortar to ensure a strong bond with the surrounding wall.

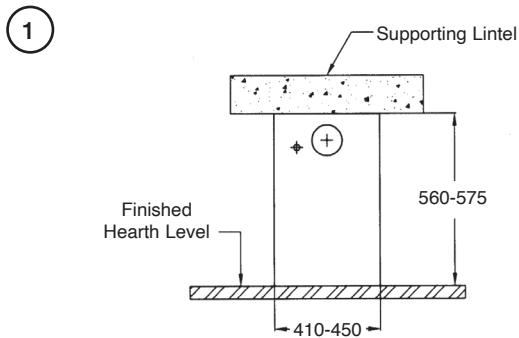

With the lintel in position mark the width of the aperture and remove the blockwork.

Seal the cavity with non-combustible board, to prevent any insulation touching the appliance.

Ensure that there is a minimum of 5mm gap left between the back of the appliance and the outer wall. **There must be no combustible materials behind this appliance.**

Mark the position of the flue on the wall by measuring from the top of the finished hearth level, see Diagram 2.

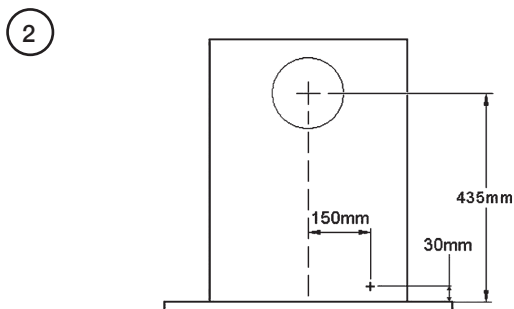

A 152mm (6") diameter hole is required to install the flue.

This can be achieved by either:

- a) Core drill
- b) Hammer and chisel

It is advisable to drill small holes around the circumference when using method b. Make good both ends of the hole.

INSTALLATION OF THE APPLIANCE

FLUE LENGTH

With the appliance secured in place, (minimum 10mm gap between the back of appliance and the wall) measure the distance from the back of the appliance to the outside face of the wall. Deduct 18mm from this measurement.

Insert the square cardboard sleeve into the flue to support the inner tube.

Cut through the flue and sleeve.

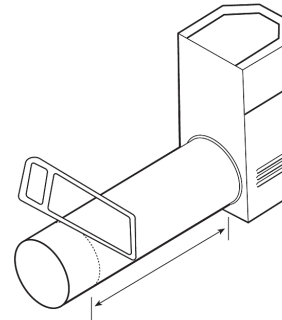

Remove the cardboard remnants from the flue.

File the cut edges smooth.

TERMINAL

On the outside wall:

Position the flue assembly into the hole. The terminal should be flat against the wall.

Make sure the terminal is vertical, see above.

Mark the 4 fixing holes.

Remove the terminal to drill the holes.

Insert wall plugs supplied.

Do not fix the flue at this stage.

FLUE AND APPLIANCE FIXINGS

Position the appliance observing appropriate clearances.

Apply a bead of suitable weatherproof sealant (silicone or similar) to perimeter of back face of terminal, see Diagram 1.

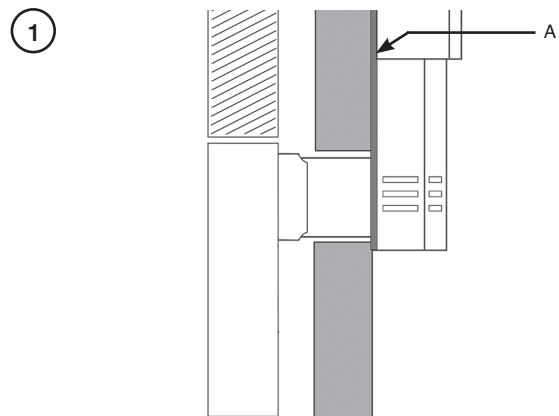

Feed the flue through the wall, making sure it runs smoothly.

Engage the flue in the inner and outer spigots.

Insert 4 screws in the flanges of the flue terminal.

Check sealant has formed a water-tight joint to the wall.

Any terminal less than 2m above any access (level ground, balcony or flat roof with access) must be fitted with the guard supplied, see Diagram 2.

2

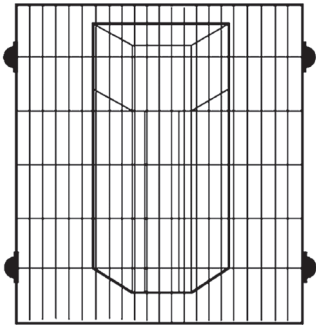

PURGE THE SUPPLY PIPE. This is essential to expel any debris that may block the gas controls. Connect the elbow to the appliance inlet pipe.

Connect a suitable pressure gauge to the test point located on the inlet elbow and turn the gas on.

Light the appliance and check for leaks.

Turn the appliance to maximum and check that the supply pressure is as stated on the databadge

Turn the gas supply off and replace the test point screw. Turn the gas on and check the test point for leaks.

FOAM SEAL (SLIDE CONTROL MODELS ONLY)

The foam seal must be fitted to the appliance prior to attaching the decorative front.

On the right hand side of the appliance, place the foam seal in the channel between the glass frame and the slide control housing, see below.

The foam seal must align with the right hand side of the glass frame and 24mm below the top of the appliance flange, see below.

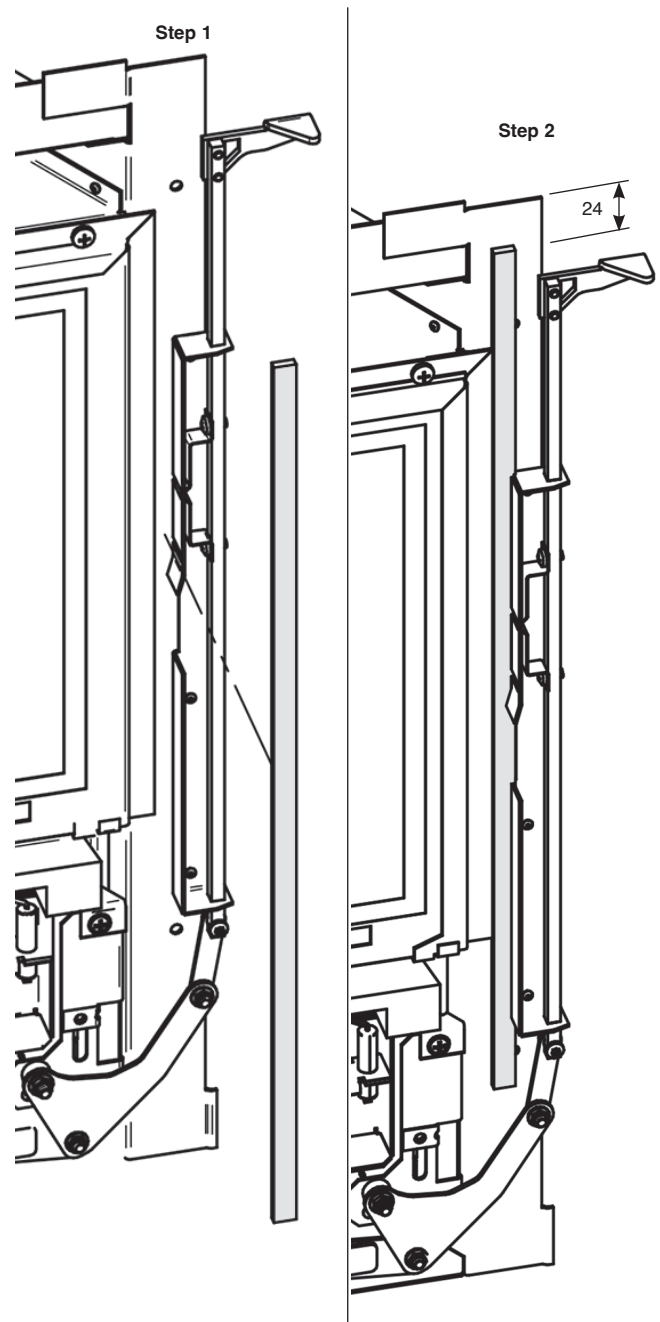

REMOVING THE GLASS FRAME

Remove the glass frame by removing the 4 screws in the retaining bracket.

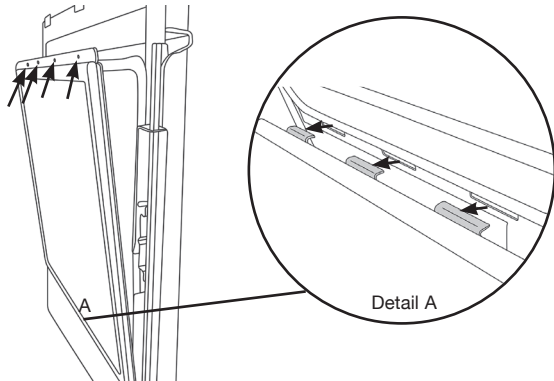

Tilt the top of the glass frame forward and disengage the lower location tabs from the slots in the firebox, see Detail A. Place carefully to one side.

ARRANGEMENT OF THE FUEL BED

ADVICE ON HANDLING AND DISPOSAL OF FIRE CERAMICS



BLACK REED LINERS

These lining panel options are available for this product and contains Refractory Ceramic Fibre (RCF), a material which is commonly used for this application.

RCF waste is classed as stable, non-reactive hazardous waste and may be disposed of at a licensed landfill site.

If replacing these items, do not break them up. Seal within heavy duty polythene bags and label as RCF waste.

Protective clothing is not required when handling these articles.

If the Liners are visibly broken Gazco recommend using gloves and a face mask to remove the pieces and remove any dust accumulated in and around the appliance before and after working on it with a HEPA filtered vacuum.

If any concerns remain contact Gazco Technical Customer Services to obtain the manufacturers COSHH Date Sheet.

LOG LAYOUT

LOGS MUST BE POSITIONED ACCORDING TO THE FOLLOWING INSTRUCTIONS TO GIVE THE CORRECT FLAME EFFECT.

Ensure the burner tray is clean and free from any debris, see Diagram 1.

Note: The LPG and Nat Gas burner trays are visually different but the log layouts are the same.

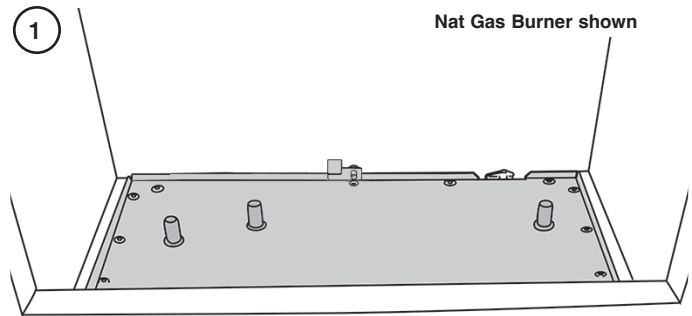

Place Log A in position on the 2 locating pins, see Diagram 2.

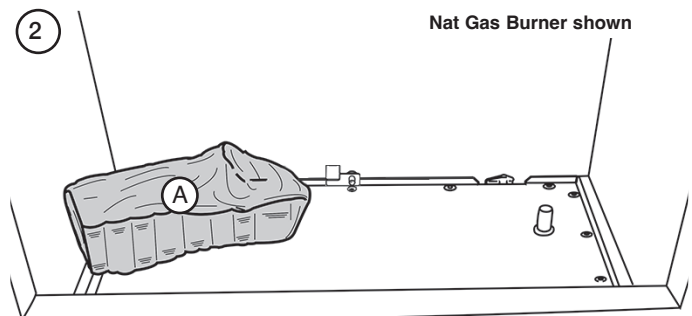

Spread the Lava Rock evenly over the fuel bed and around Log A, see Diagram 3.

Ensure that the fuel effect does not obstruct the pilot.

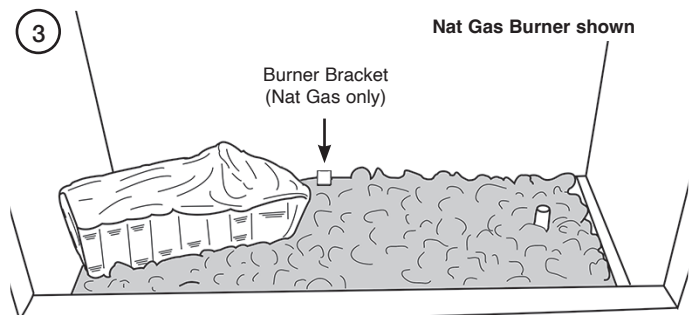

Log B is positioned on the right hand locating pin, and rests against the back liner, see Diagram 4.

Nat Gas only - ensure that the left hand side rests on the burner bracket, see Diagrams 3 & 4.

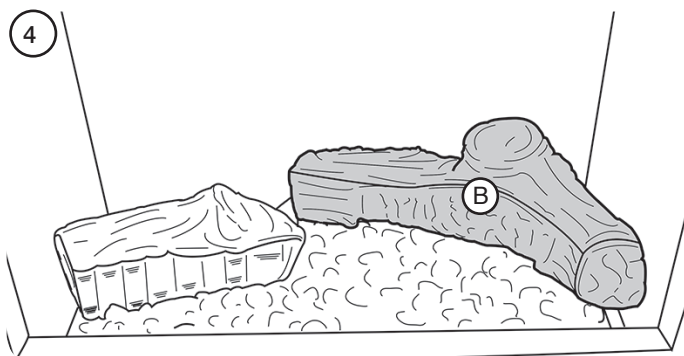

Log C rests on Log A and the front tray with the locating pin facing up, see Diagram 5.

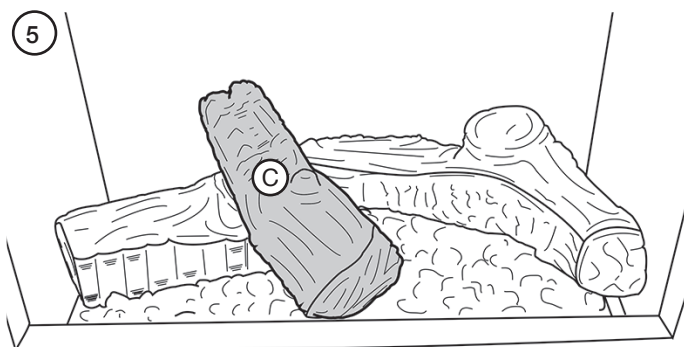

Log D fits onto the locating pin and rests on Log B, see Diagram 6.

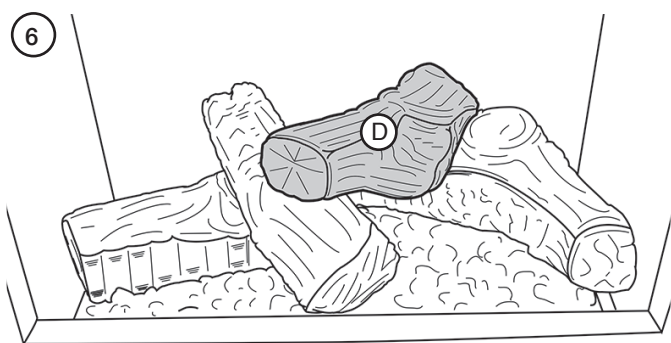

Position the 2 embers in the front right and back left corners, see Diagram 7.

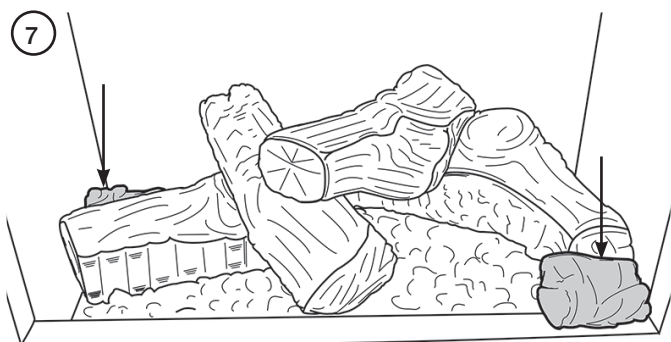

Springly spread an amount of the Embaglow fibres provided on the sections highlighted, see Diagram 8.

Take care not to use more than half a packet per application.

WARNING - DO NOT PLACE NEAR THE PILOT AREA.

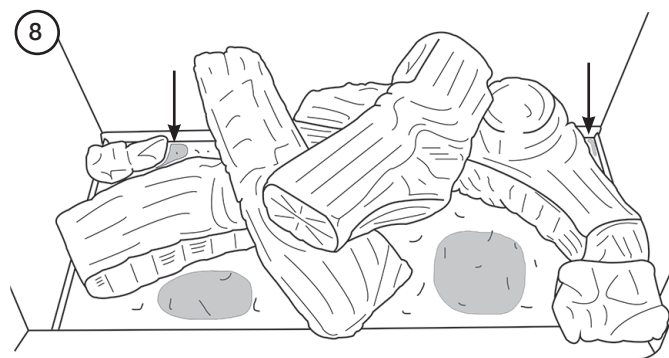

FITTING THE GLASS FRAME

Ensure that the rope seal on the box is intact, then locate the glass frame location tabs into the slots on the firebox, see Detail A.

Secure the glass frame using 4 screws in the retaining bracket. Replace ALL of the glass frame securing screws ensuring that a screw is present in all fixing slots.

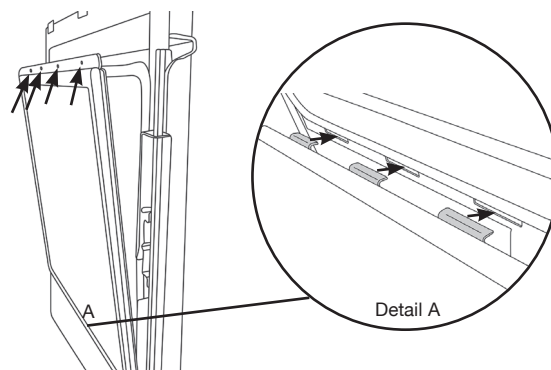

NEVER OPERATE THE APPLIANCE WHEN THE GLASS FRAME IS REMOVED OR BROKEN.

Refer to the separate decorative front Instructions to replace the front on the appliance.



UNDER NO CIRCUMSTANCES SHOULD THE APPLIANCE BE USED IF ANY OF THE GLASS FRAME RETAINING SCREWS ARE LOOSE OR MISSING.

OPERATING THE APPLIANCE

There are 2 types of control systems available for this appliance:

1. Manual and Remote Control
2. Slide Control

Follow the relevant section for specific operation.

1. MANUAL AND REMOTE CONTROL

There are two ways of lighting the appliance:

- a) Using the Manual Controls on the Control Box (located on the appliance).
- b) By thermostatic remote control.

1A. MANUAL OPERATION (CONTROL BOX)

The manual controls are located on the Control Box at the bottom of the appliance, behind the ash cover, see Diagram 1.

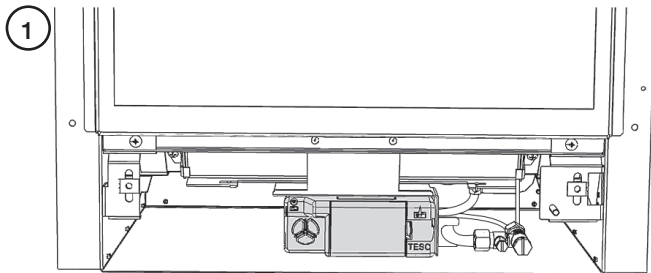

There are a series of buttons on the left hand side of the Control Box, see Diagram 2.

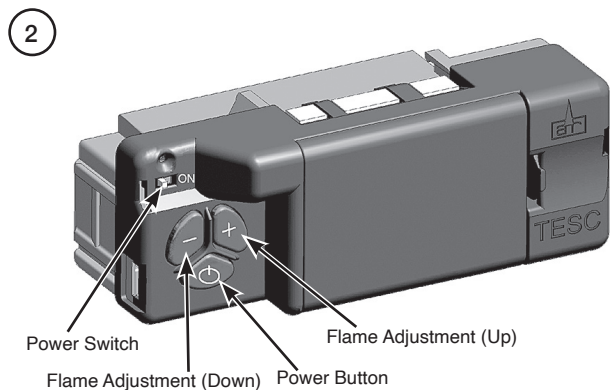

To operate the appliance the Power Switch on the Control Box must be switched ON.

i **Note:** The Power Switch does not need to be turned off each time the appliance is not in use. However, if the appliance is left unattended for long periods of time (e.g. vacation), it is recommended to place the Power Switch into the off position.

TURNING THE APPLIANCE ON

Press and hold the Power Button for 1 second and release. The burner will light within 2 seconds.

Use + and - buttons to adjust the flame height between Minimum and Maximum.

TURNING THE APPLIANCE OFF

Press the power button to turn the appliance off.



IMPORTANT: YELLOW FLAMES TYPICALLY APPEAR WHEN THE APPLIANCE HAS REACHED NORMAL OPERATING TEMPERATURE. THIS CAN TAKE UP TO 30 MINUTES.



WARNING: IF THE APPLIANCE FAILS TO LIGHT OR BECOMES EXTINGUISHED IN USE, WAIT 3 MINUTES BEFORE ATTEMPTING TO RELIGHT.

THE APPLIANCE MAY TAKE SEVERAL AUTOMATIC ATTEMPTS TO RESTART. DO NOT INTERRUPT THE VALVE DURING THIS PROCESS.

1B. REMOTE CONTROL

To operate the appliance the Power Switch on the Control Box must be switched ON (1).

To activate the Remote Control it will be necessary to cradle the handset to unlock. The green light will illuminate to show the handset is ready to use.



IMPORTANT: Continue to cradle the handset throughout an operation to keep it unlocked. If the green light goes off during an operation it will be necessary to reposition the handset so the light comes back on and restart the operation.

HANDSET FEATURES

Mode: Man (Manual), Zzz (Timer)
Thermostat or Timed

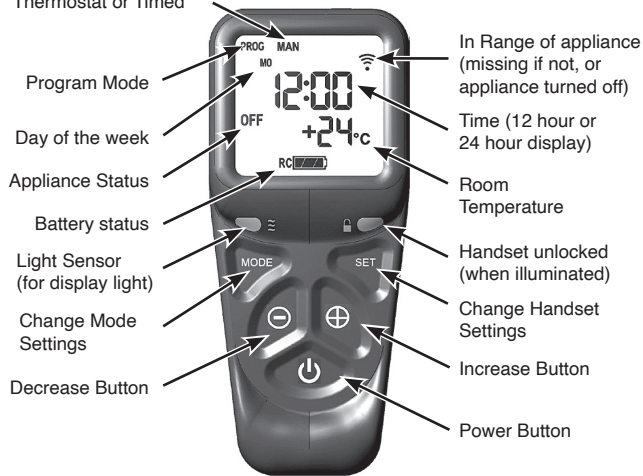

The Handset provided with the fire should have been factory paired with the Control Box. If not, see Installation Instructions — Pairing the Appliance.

HANDSET INITIAL SET UP

Following initial set up or new pairing it will be necessary to set the time and date.

i **NOTE: Pressing SET button will advance the display to the next screen and pressing MODE button will return it to the previous setting.**

SETTING THE TIME

Once the handset is paired the screen will show that the time is not yet set. The handset will then automatically progress to the next setup screen.



SETTING THE DISPLAY FOR 12- OR 24-HOUR CLOCK

Holding the remote to keep the green light on and the handset unlocked, the handset will display H:24.



24 denotes a 24-hour clock and 12 denotes a 12-hour clock. Press the + or - button on the handset to toggle between the two settings.

Press the SET button to confirm and progress to setting the day of the week.

SETTING THE DAY OF THE WEEK

Press and release the + and - buttons until the correct day of the week is shown on the display.



Mo = Monday, **Tu** = Tuesday, **We** = Wednesday, **Th** = Thursday, **Fr** = Friday, **Sa** = Saturday and **Su** = Sunday.

Press SET to confirm the day of the week and progress to setting the time.

SETTING THE HOUR

Press and release the + or - button to change the hour to the correct hour. Press SET to confirm and progress to setting the minute.



SETTING THE MINUTES

Repeat the process to change the minutes.

SETTING THE TEMPERATURE DISPLAY (CELSIUS OR FAHRENHEIT)

Press and release the + or - button to toggle between C and F. When the display shows the desired symbol, press and release the SET button to store.



Place the handset down and wait until the home screen is displayed and the unlock light goes off.

The Handset is now ready to operate the appliance.

ADVANCED MENU SETTINGS

It is possible to change additional preset settings of the control features.

ACCESS THE ADVANCED MENU SETTINGS.

Press and release the SET button to enter the Advanced Settings Menu.

Advanced Settings are:

Back Light (L)

- A = Automatic (default setting).
The backlight comes on in the dark.
- O = Light never comes on.
- 1 = Light comes on when the handset is unlocked.

Display Contrast (C)

- 8 Levels from 0 - 7 (Default level 4).

P = Pairing with devices other than the Control Box.
This feature is not available on this appliance.



IMPORTANT: ALL THE NECESSARY SETTINGS REQUIRED HAVE NOW BEEN COMPLETED. ANY FURTHER FUNCTIONS ON THIS HANDSET ARE FOR FACTORY SETTING AND NOT TO BE USED.

PLACE THE HANDSET ON A FLAT SURFACE AND WAIT UNTIL THE HOME SCREEN IS DISPLAYED AND THE UNLOCK LIGHT TURNS OFF.

OPERATING THE APPLIANCE

TURNING THE APPLIANCE ON

Press the Power Button until Pilot flashes on the display. Release the Power Button and the Flame symbol will appear on the display.

If the button is held the command will be cancelled for safety reasons.

Holding the handset to unlock, use + and - buttons to adjust the flame height between Minimum and Maximum.



TURNING THE APPLIANCE OFF

Holding the handset to unlock, press the power button to turn the appliance off.



IMPORTANT: YELLOW FLAMES TYPICALLY APPEAR WHEN THE APPLIANCE HAS REACHED NORMAL OPERATING TEMPERATURE. THIS CAN TAKE UP TO 30 MINUTES.

WARNING: IF THE APPLIANCE FAILS TO LIGHT OR BECOMES EXTINGUISHED IN USE, WAIT 3 MINUTES BEFORE ATTEMPTING TO RELIGHT.

THE APPLIANCE WILL TAKE 3 AUTOMATIC ATTEMPTS TO RESTART. DO NOT INTERRUPT THE VALVE DURING THIS PROCESS.

i If the handset has been replaced or the fire serviced, it will need repairing, see Installation Section: Pairing the appliance – Remote Control Version Only.

CHECKING IF HANDSET NEEDS REPAIRING

Stand a meter from the appliance.
Pick up the Handset and cradle it to unlock.



If there is no  symbol in the top right corner of the home screen or the error message TESCR5 (below) is showing the handset needs repairing.



RESETTING THE REMOTE TO FACTORY SETTINGS

It may be necessary to reset the remote to factory settings to pair to a new control valve.

Cradle the handset to unlock.
The green light must be illuminated for the handset to accept commands.



Press and hold SET until the handset beeps.
Release the SET button. PROG will be shown in the top left corner.

Press and release the MODE button until the word SETUP is flashing in the top right corner.

Press and release SET to enter the SETUP menu.

Press and release the SET button around 9 times until you see CA0 on the display screen.



Press then release the + (or -) button to change the display to CA1.



Press and release the SET button again.

The handset will display the following when it is ready to pair with a new control valve:



PAIRING THE APPLIANCE - REMOTE CONTROL VERSION ONLY

It may be necessary to pair the handset to the appliance following servicing.

Ensure the Power switch on the Control Box is in the ON (I) position.

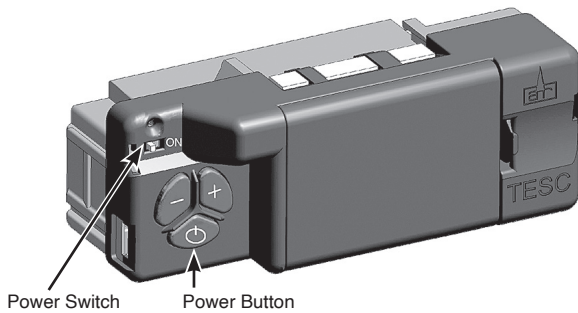

Cradle the handset to unlock.
The green light must be illuminated for the handset to accept commands.
Reset handset to Factory Settings.



Once done, simultaneously press and hold the - and + buttons on the Control Box until the red light appears on the Control Box.

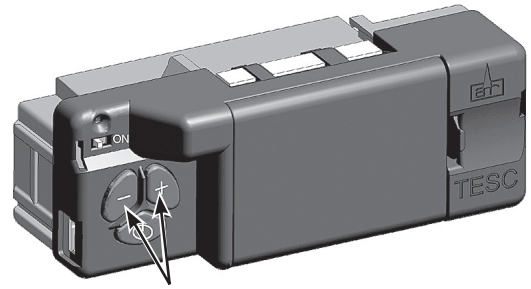

WARNING: IF THE + AND - BUTTONS ARE DEPRESSED FOR 20 SECONDS OR MORE THE LIGHT WILL EMIT A SLOW STEADY PULSE. FURTHER ACTIONS WILL REMOVE ANY HANDSET PAIRING.

Release the - and + buttons and within 1 second press the Power Button on the Control Box.

The handset emits a short beep, the green light on the handset flashes and the following icon is displayed.



With the display showing the icon, press and hold the SET button to pair the handset to the appliance.

Following new pairing it will be necessary to set the time and date, see Installation Instructions.

If too much time passes without the SET command the display will show the following.



The handset has not paired and the process will need to be started again.

SUPPORT VIDEOS

For help with pairing and using your TESC5 valve and remote control, please scan the QR code or visit Stovax.com.



TROUBLESHOOTING

See Page 11 for help with troubleshooting errors.

2. SLIDE CONTROL

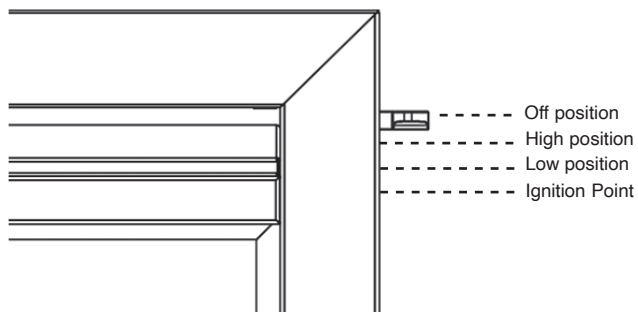
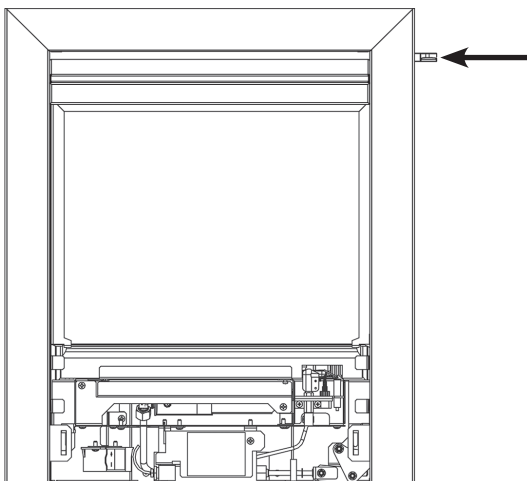

LIGHTING THE PILOT

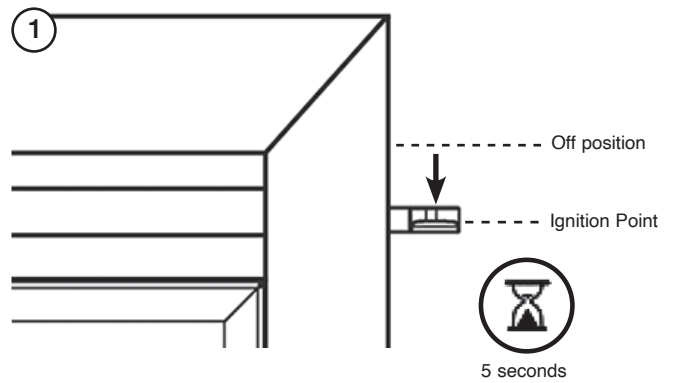

The appliance should light on its lowest setting. Repeat the above steps if the appliance does not light.

ADJUSTING THE FLAME HEIGHT

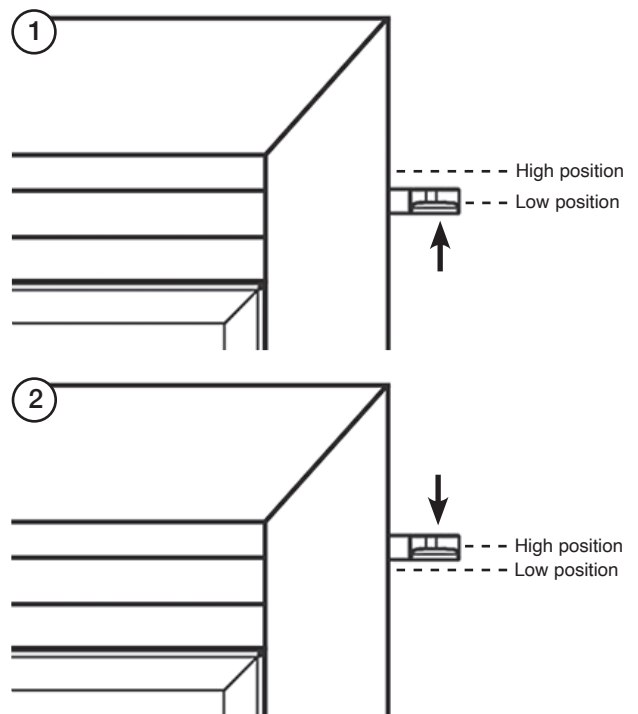

IMPORTANT: YELLOW FLAMES TYPICALLY APPEAR WHEN THE APPLIANCE HAS REACHED NORMAL OPERATING TEMPERATURE. THIS CAN TAKE UP TO 30 MINUTES.



WARNING: IF THE APPLIANCE FAILS TO LIGHT OR BECOMES EXTINGUISHED IN USE, WAIT 3 MINUTES BEFORE ATTEMPTING TO RELIGHT.

SWITCHING OFF THE APPLIANCE

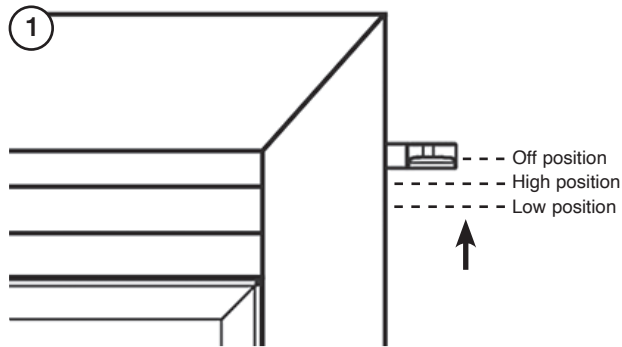

See Servicing to replace Slide Control.

COMMISSIONING

Complete the Commissioning Checklist at the front of this manual covering:

- Thermocouple soundness checks. This is to include ensuring the thermocouple is secure on the pilot bracket assembly, lead connection and integrity.
- Flue checks
- Gas checks
- Fuel effect layout - flame picture

Upon completion of the commissioning and testing of the installation and correct operation of the appliance, the installer must instruct the user how to operate the appliance.

Guide the user through the User Instructions paying particular attention to:

- a) Regular servicing (See User Instructions).
- b) Ventilation (See Page 15) - point out the ventilation positions where applicable.
- c) Hot surfaces (See Page 15).

SERVICING/FAULT FINDING CHARTS

SERVICING REQUIREMENTS

IMPORTANT – The glass panel on this appliance should be checked for any signs of damage on the front face of the glass panel (scratches, scores, cracks or other surface defects). If damage is observed, the glass panel must be replaced and the appliance must not be used until a replacement is installed. Under no circumstances should the appliance be used if any damage is observed. Please isolate the appliance until a replacement glass panel has been obtained and installed. Replacement glass panels can be purchased from Gazco via the retailer from which the appliance was purchased or any other Gazco distributor.

This appliance must be serviced at least once a year by a competent person.

All tests must be carried out in accordance with the current GasSafe recommendations.

BEFORE TESTING

- Conduct a gas soundness test for the property ensuring there are no leaks before servicing.
- Check the operation of the appliance before testing.

SPECIAL CHECKS

- Clean the burner using a vacuum cleaner with a soft brush attachment. Ensure all debris is removed from the burner ports.
- Check the flue terminal position complies with the requirements, and that the terminal is not obstructed.
- Clean away any debris under the burner.
- Check the condition of ceramics, pilot and burner cover gasket.
- Ensure that the glass frame is secured correctly and that all retaining screws are in place.

Correct any faults found during the initial tests

Re-commission the appliance in accordance with Commissioning Procedures of these instructions.

Advise the customer of any remedial action taken.

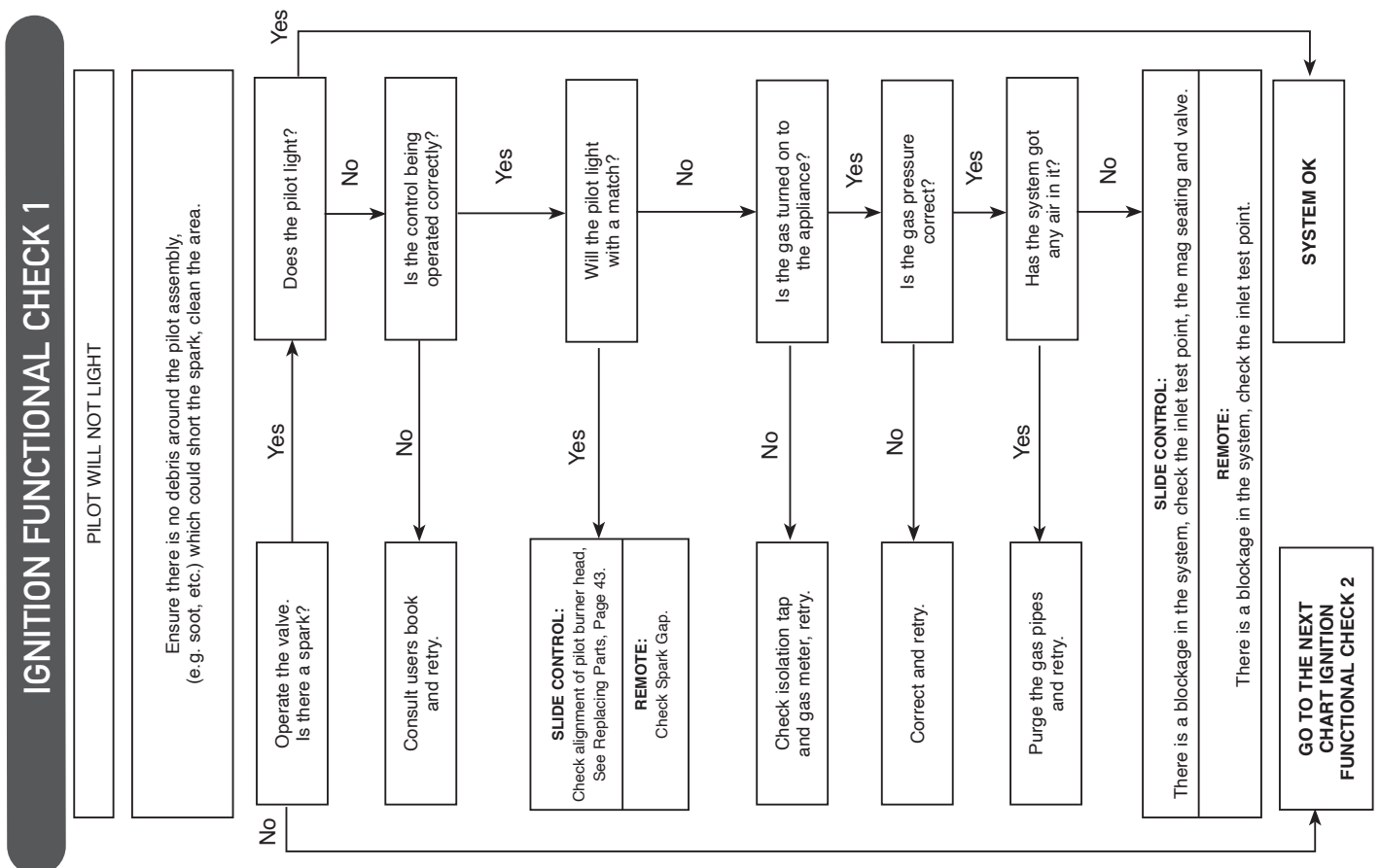

FAULT FINDING CHARTS

IGNITION FUNCTIONAL CHECK 2B SLIDE CONTROL

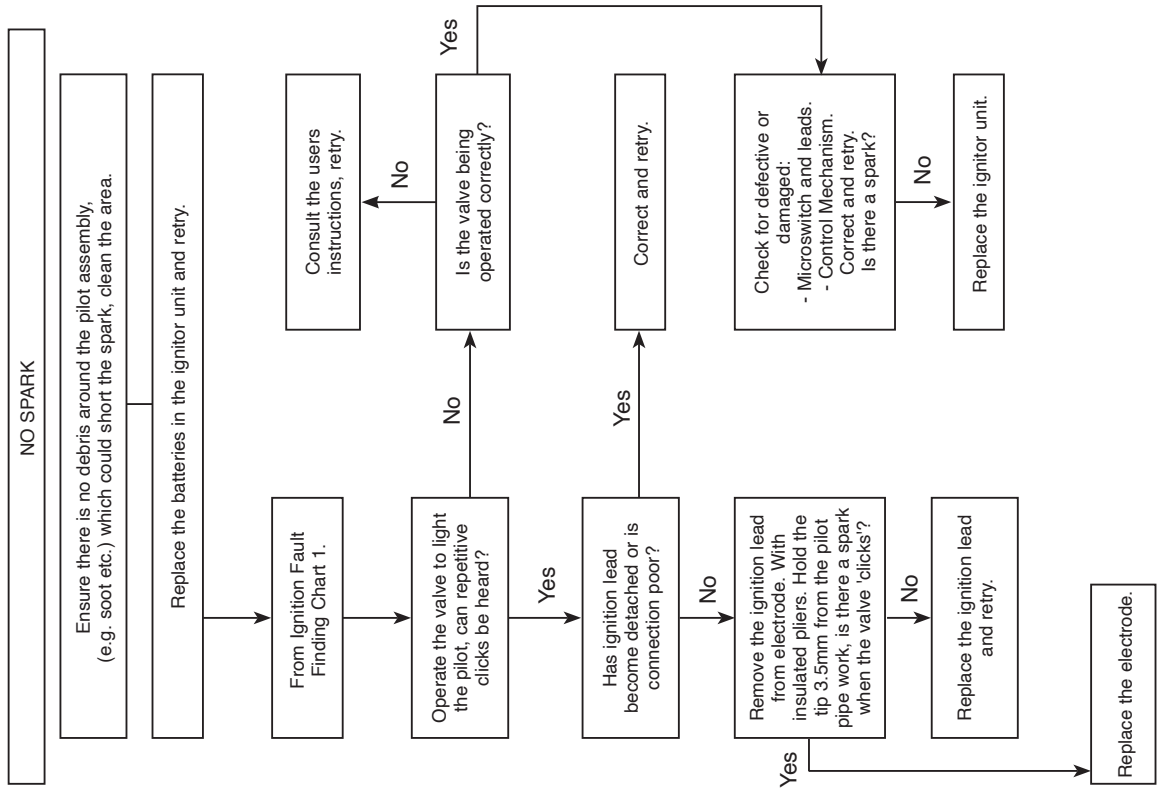

IGNITION FUNCTIONAL CHECK 2A REMOTE

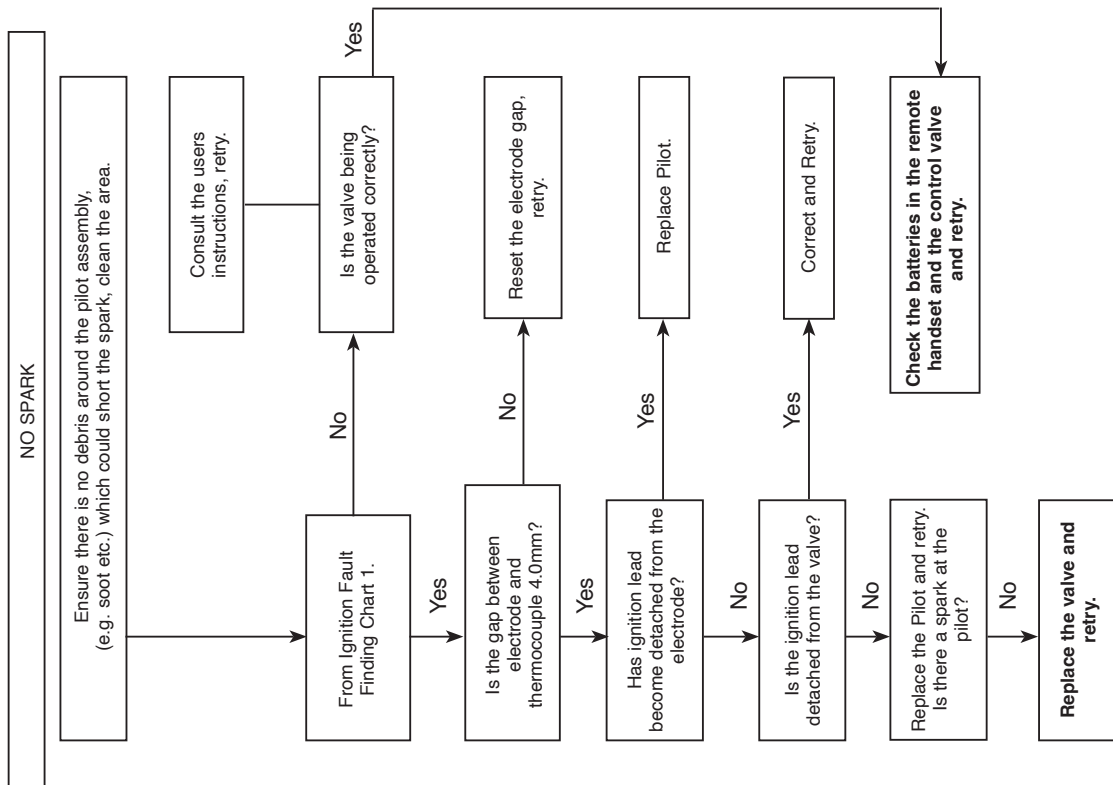

FAULT FINDING CHARTS

FLAME FAILURE FUNCTIONAL CHECK 3B
SLIDE CONTROL

PILOT WILL NOT STAY LIT OR APPLIANCE GOES OUT IN USE

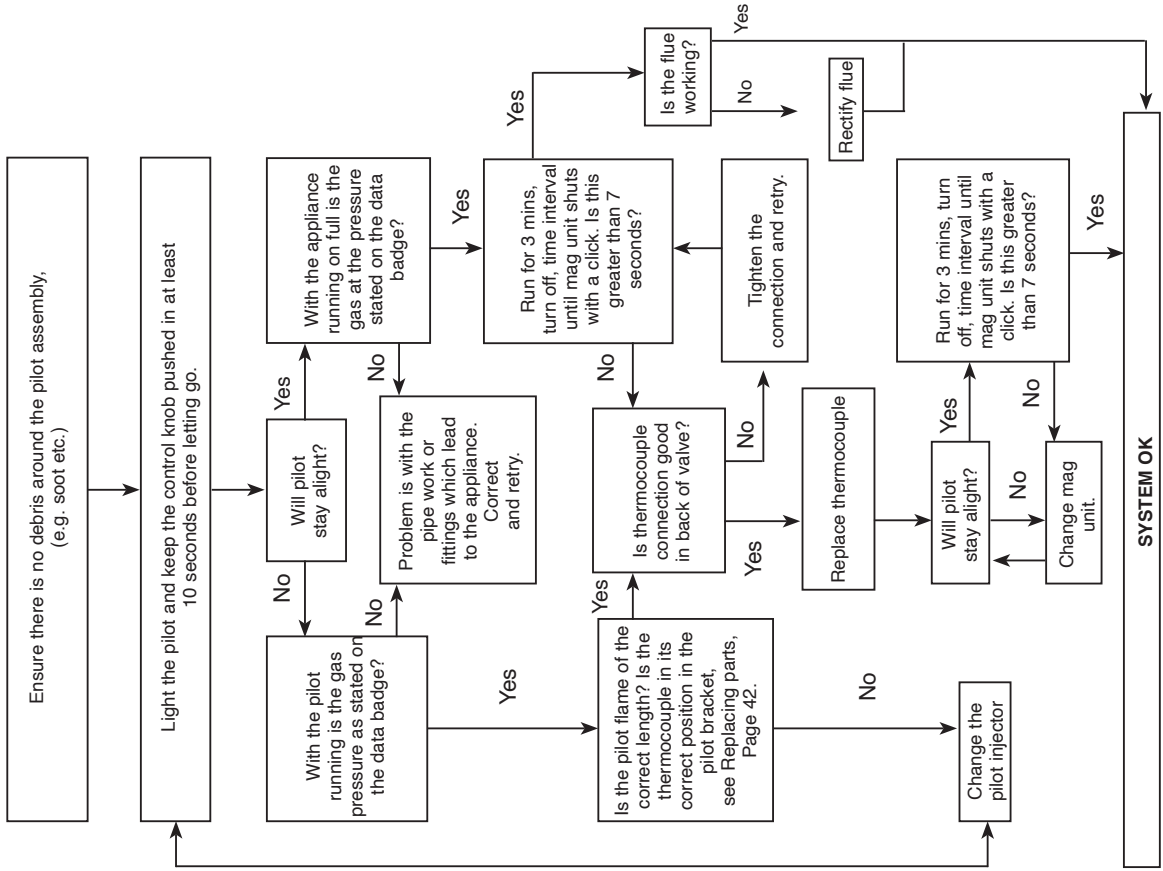

FLAME FAILURE FUNCTIONAL CHECK 3A
REMOTE

PILOT WILL NOT STAY LIT OR APPLIANCE GOES OUT IN USE

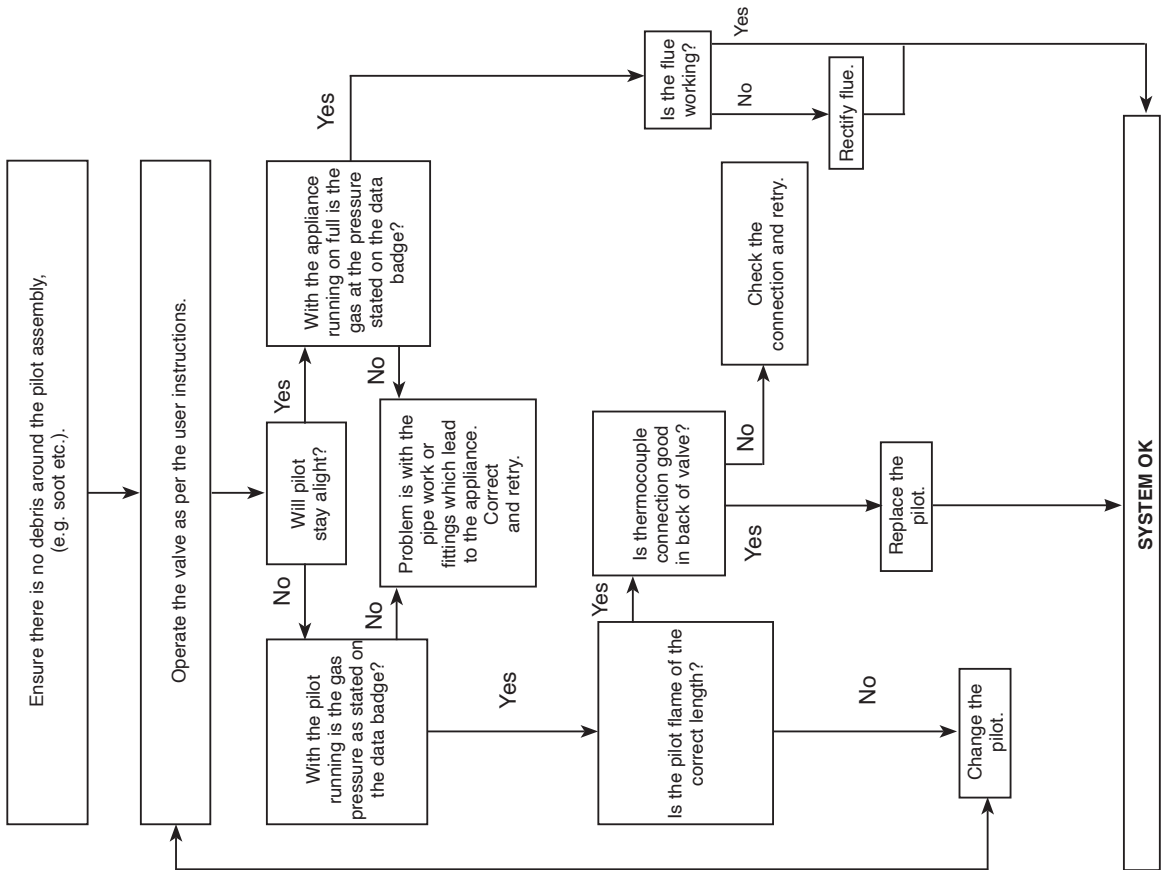

FAULT FINDING CHARTS

ELECTRONIC CONTROL VALVE FAULT ANALYSIS

RED INDICATOR	MEANING
Permanently lit	Valve tried to light but failed and in LOCKOUT E00
Flashing very fast	Valve is busy (will not accept any command)
Flashing once a second	Valve detects an error
Flashing once every 10 seconds	Indication of low battery power in valve
Flashing twice every 10 seconds (handset only)	Indication of low battery power in handset and valve
Permanently off	Valve in standby or in a stable operation
On momentarily after power up	Valve doing a self test
Appears after pressing start	Indicates time to release pressing the start button

If the valve indicates an error:

Allow the appliance to cool (if hot).

Check the battery status and replace with new if in any doubt.

Reset the error by first pressing the power button (with the appliance cool).

Press once again to start the fire.

If the error persists, refer to the Troubleshooting section on Page 11.

SERVICING INSTRUCTIONS - REPLACING PARTS

GENERAL

All principal components can be replaced without removing the appliance from its installation, although it is essential that the gas supply to the appliance is turned off at the isolation device before proceeding further.

Before replacing some of the components it will first be necessary to remove the burner assembly from the appliance by following the instructions below.

REMOVING THE GLASS FRAME

Ensure the appliance is cold before proceeding.

Turn the gas supply off at the isolation device. Then disconnect the supply pipe.

Remove the decorative front from the appliance by referring to the separate instructions supplied.

Remove the glass frame by removing the 4 screws in the retaining bracket, see Diagram 1.

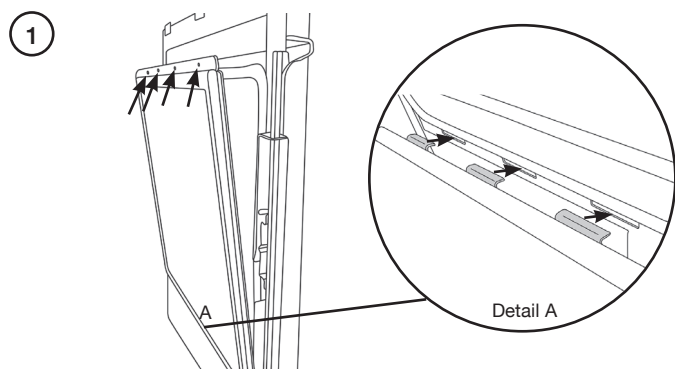

Tilt the top of the glass frame forward and disengage the lower location tabs from the slots in the firebox, see Diagram 1, Detail A. Place carefully to one side.

Remove the logs and Embaglow and place on a dry, clean surface.

The glass frame must be refitted to the appliance following cleaning or servicing. Ensure that the rope seal on the box is intact, then locate the glass frame location tabs into the slots on the firebox, see Diagram 1, Detail A.

Secure the glass frame using 4 screws in the retaining bracket, see Diagram 1.

Replace ALL of the securing screws ensuring that a screw is present in all fixing slots.

NEVER OPERATE THE APPLIANCE WHEN THE GLASS FRAME IS REMOVED OR BROKEN.

Refer to the separate decorative front instructions to replace the front on the appliance.



UNDER NO CIRCUMSTANCES SHOULD THE APPLIANCE BE USED IF ANY OF THE GLASS FRAME RETAINING SCREWS ARE LOOSE OR MISSING.

APPLIANCE BATTERY

REMOTE CONTROL

It is not necessary to remove the appliance battery to service the appliance, however the Power Switch on the Control Box must be switched to the OFF position.

The Power Switch is located on the Control Box at the bottom of the appliance behind the ash cover.

Slide the Power Switch on the Control Box to the OFF position before servicing the appliance.

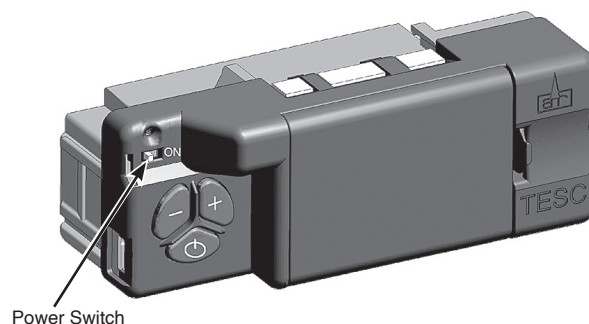

SLIDE CONTROL

Remove the battery before carrying out work on this appliance.

The appliance battery is located at the bottom left of the appliance behind the ash cover.

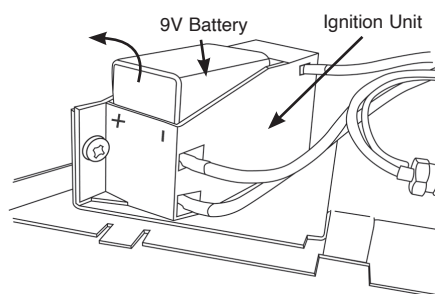

MAIN BURNER

Remove the 2 screws at the front of the burner tray, see Diagram 1.

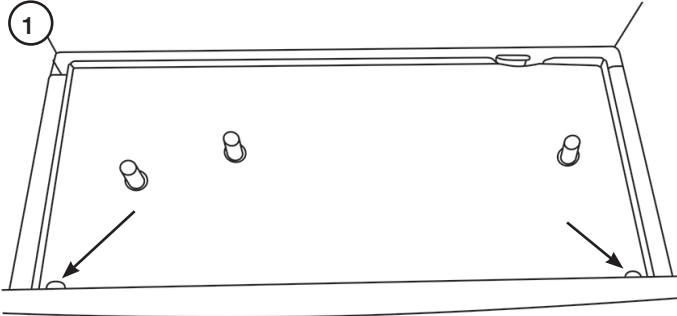

Lift the left hand side of the burner tray, before lifting the right hand side, see Diagram 2.

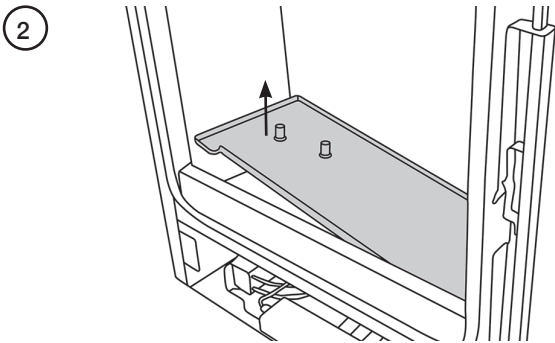

Slide the burner tray fully to the left and remove through the front of the firebox, see Diagram 2.

CONTROL ASSEMBLY

It will be necessary to remove the bottom section of the glass frame seal from the appliance.

Push the arrow-headed spring clips out of the body. It may be necessary to slightly compress the clips to ease removal, see Detail A.

NOTE: Only the lower 7 clips need to be removed.

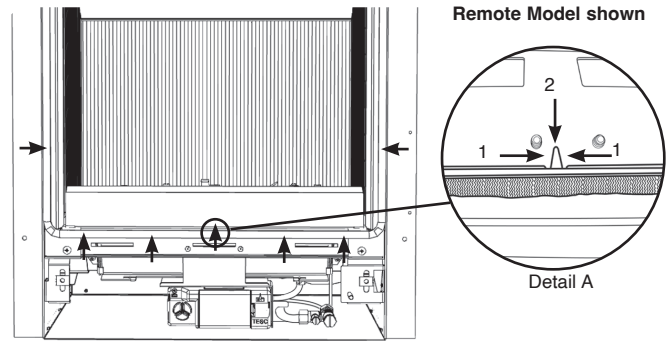

SLIDE CONTROL ONLY

Remove the M4 lock nut and spacer securing the slider arm to the appliance and loosen the 2 nuts.

Ensure that the spacer is retained and replaced when the control assembly is reinstalled.

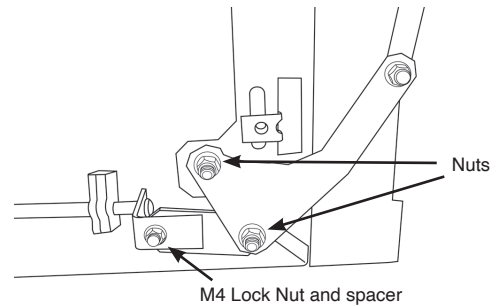

ALL MODELS

Remove the 2 screws positioned either side of the Control Box bracket, see Diagrams 1 & 2.

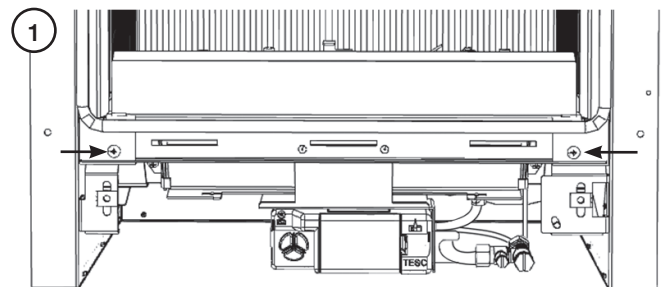

Remote Model

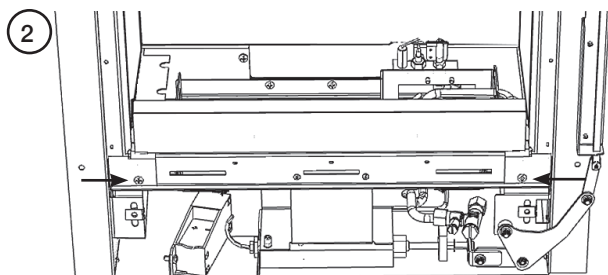

Slide Model

Slide Control Models: Take care not to catch the slide mechanism when removing the burner.

The burner unit can now be removed from the appliance. Lift the front of the assembly up and out from the appliance. Take care not to damage the door seal.

Take care not to damage the liners.

Replace in reverse order.

When refitting the Control Assembly ensure that the foam seal is flat against the appliance body, see Diagram 3.

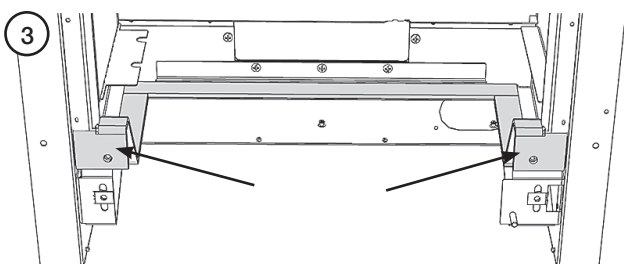

Remote Model shown

Ensure the rear of the tray slides under the retaining bracket on the rear of the appliance, see Diagram 4.

NOTE: The burner unit and pipe work have been removed for clarity.

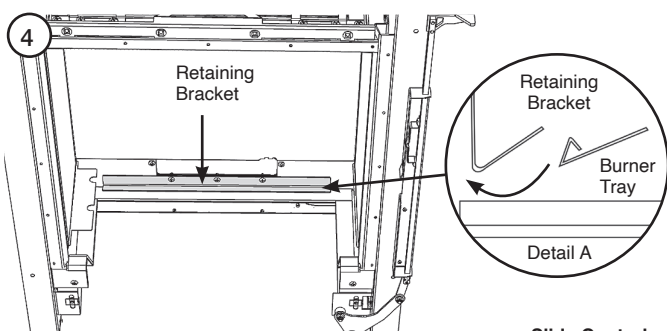

Slide Control model shown

IGNITION LEAD

The different control versions of this appliance have different servicing requirements for the Ignition Lead. Follow the relevant section for each product.

REMOTE CONTROL

The Ignition Lead used on this appliance cannot be replaced individually. If a new lead is required it will be necessary to change the pilot unit, see Page 42.

SLIDE CONTROL

Disconnect the ignition lead from the ignition unit and the pilot unit, see Diagram 1.

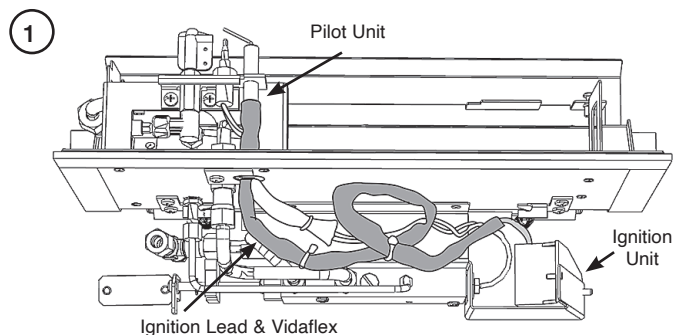

Remove the screw and sealant from plate, see Diagram 2.

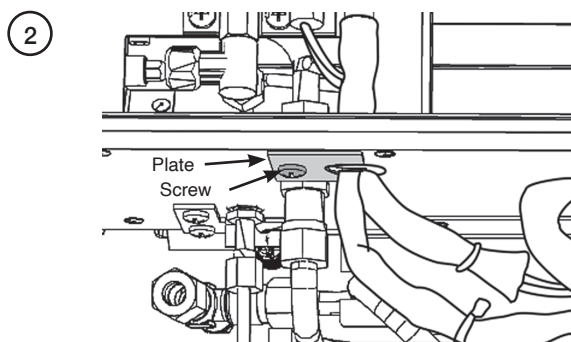

When replacing the cover plate ensure silicone sealant is used to seal the aperture.

Feed ignition lead complete with vidaflex through metal plate.

Remove the vidaflex from the old ignition lead.

Refit the vidaflex cover over the new ignition lead and fit following the same route as the old one.

Refit the Control Assembly.

Check the operation of the new ignition lead.

Reassemble the appliance.

PILOT UNIT



IMPORTANT: UNDER THE TERMS OF THE EXTENDED WARRANTY IT WILL BE COMPULSORY TO CHANGE THE COMPLETE PILOT UNIT ON THIS APPLIANCE IN YEARS 2, 4 AND 6.

Note: The pilot unit on the appliance is a non-serviceable unit due to the complex nature of its manufacture.

Replacement of the complete unit must be carried out when one of the following items becomes faulty:

- Pilot injector
- Ignition electrode
- Thermocouple
- Ignition Lead (Remote Control Models only)

Remove the Main Burner and Control Assembly, see Page 40.

REMOTE CONTROL

Undo the pilot pipe from the pilot unit, see Diagram 1.

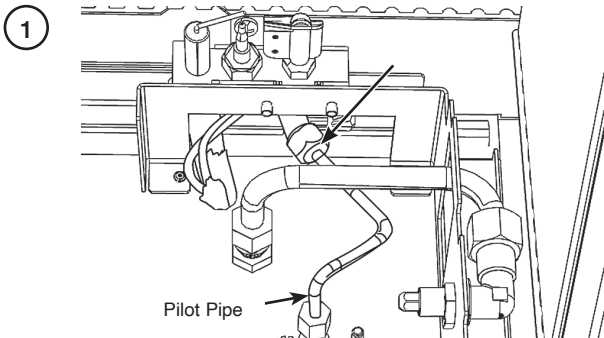

Undo the red and green thermocouple connections (A) and the white ignition lead (B) from the gas valve, see Diagram 2.

NOTE: Ensure the correct orientation when replacing, see Diagram 2 detail.

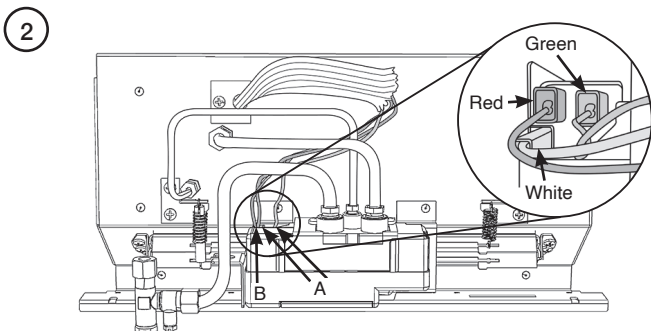

Remove the screw and sealant from plate, see Diagram 3.

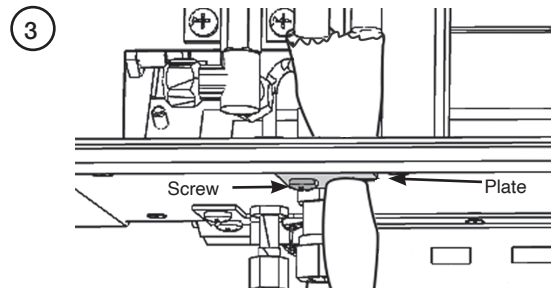

When replacing the cover plate ensure silicone sealant is used to seal the aperture.

Gently bend the tabs back to remove the pilot cage, see Diagram 4.

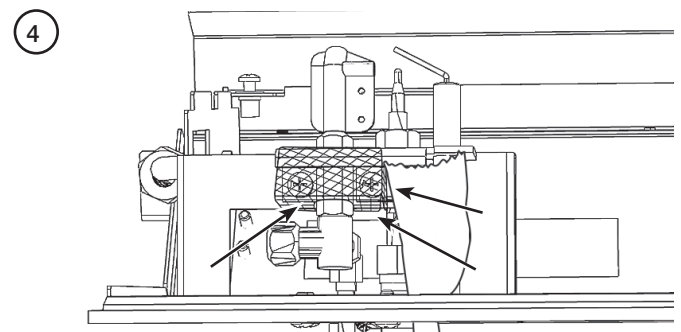

Remove the 2 screws securing the pilot assembly, see Diagram 5.

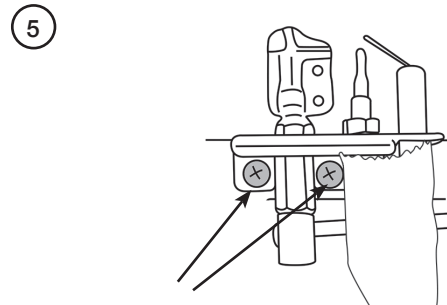

Replace with a new pilot assembly and check the spark gap, see Diagram 6.

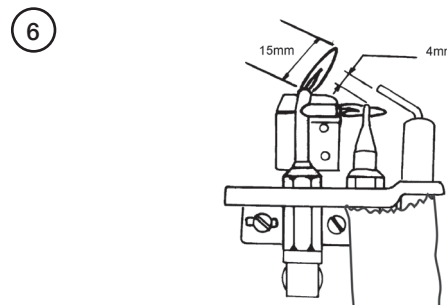

NOTE: Ensure the correct orientation when replacing.

After reassembly check for gas soundness and carry out a flame failure functional check as detailed in the Fault Finding chart, especially the time it takes for the mag unit to close.

SLIDE CONTROL

Undo the pilot pipe from the pilot unit, see Diagram 1.

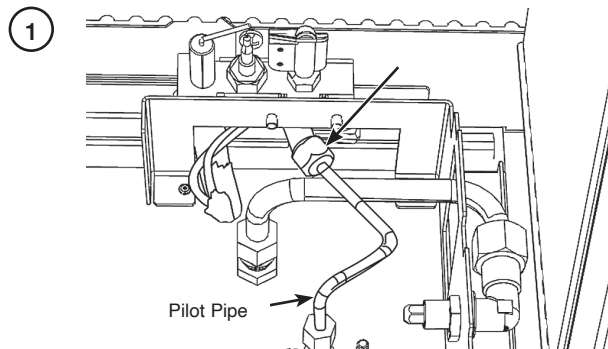

Undo the thermocouple connection from the gas valve, see Diagram 2.

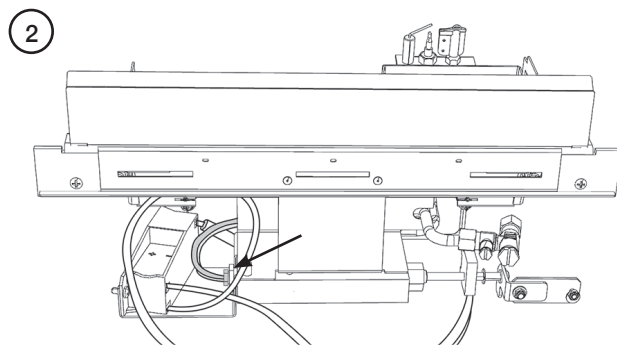

Remove the screw and sealant from plate, see Diagram 3.

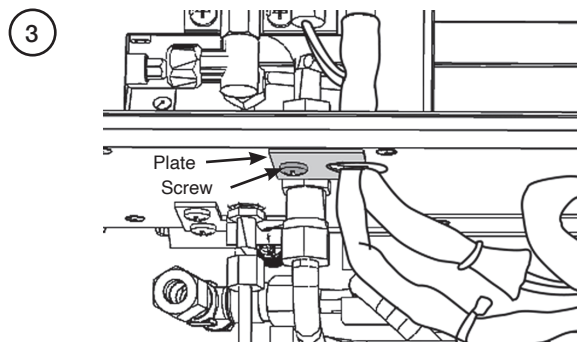

When replacing the cover plate ensure silicone sealant is used to seal the aperture.

Gently bend the tabs back to remove the pilot cage, see Diagram 4.

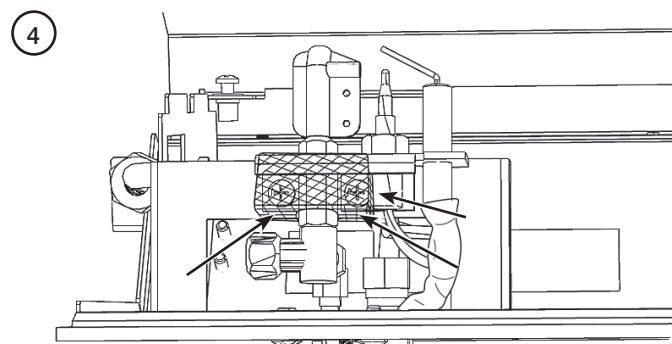

Gently pull the ignition lead off the electrode, see Diagram 5, Arrow A.

Remove the 2 screws securing the pilot assembly, see Diagram 5, Arrow B.

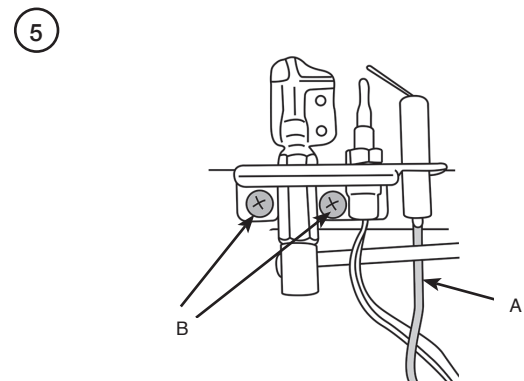

Replace with a new pilot assembly and check the spark gap, see Diagram 6.

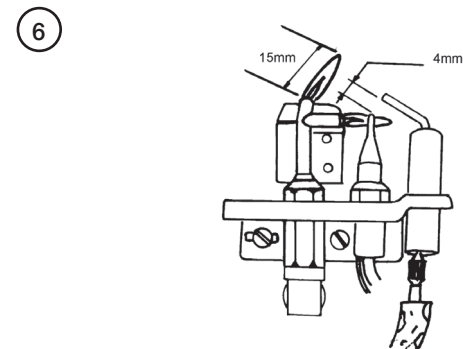

After reassembly check for gas soundness and carry out a flame failure functional check as detailed in the Fault Finding chart, especially the time it takes for the mag unit to close.

GAS VALVE

REMOTE CONTROL

To remove the gas valve first remove the red and green thermocouple connections, see Diagram 1, Arrow A.

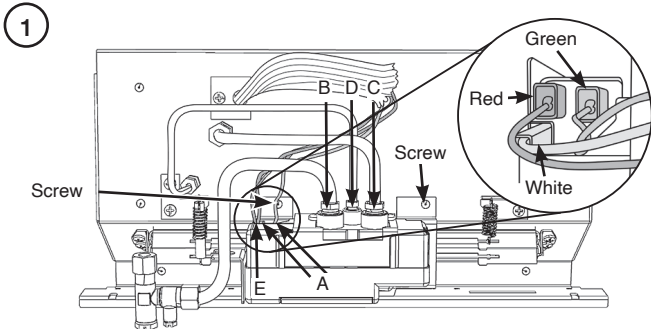

Undo the inlet pipe from the gas valve, see Diagram 1, Arrow B.

Undo the main injector feed pipe from the gas valve, see Diagram 1, Arrow C.

Undo the pilot pipe from the gas valve, see Diagram 1, Arrow D.

Disconnect the ignition lead from the gas valve, see Diagram 1, Arrow E.

Undo 2 screws securing the gas valve to the bracket, see Diagram 1.

The gas valve can now be slid forward to remove from the burner unit.

To replace the gas valve reverse the above procedure.

NOTE: Ensure the correct orientation of the connections when replacing, see Diagram 1 detail.

Check for gas leaks.

SLIDE CONTROL

To remove the gas valve first remove the thermocouple, see Diagram 1.

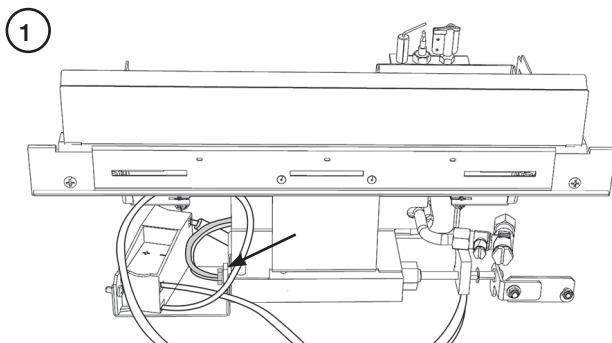

Undo the pilot pipe from the gas valve, see Diagram 2, Arrow A.

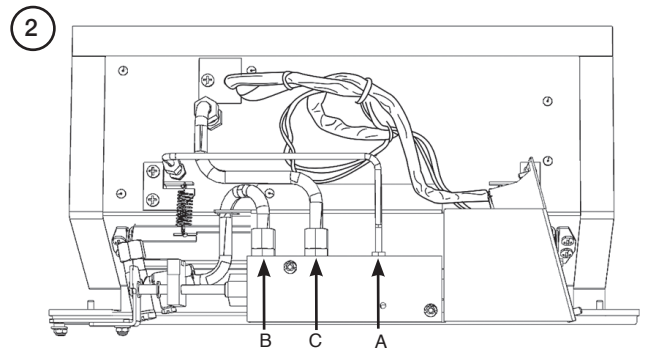

Undo the inlet pipe from the gas valve, see Diagram 2, Arrow B.

Undo the main injector feed pipe from the gas valve, see Diagram 2, Arrow C.

Disconnect the 2 leads from the micro-switch, see Diagram 3.

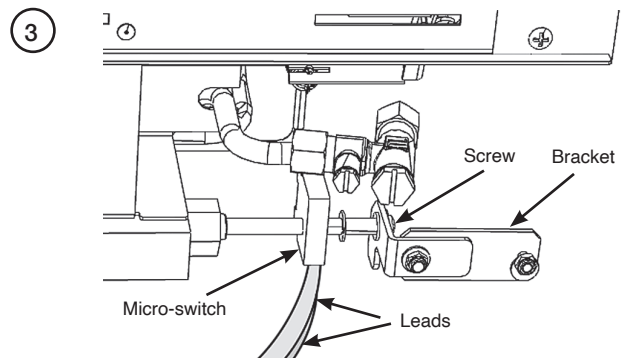

Undo the screw from the end of the spindle and remove the bracket, see Diagram 3. Ensure bracket is replaced during reassembly.

Remove the 2 screws from the gas valve, see Diagram 4.

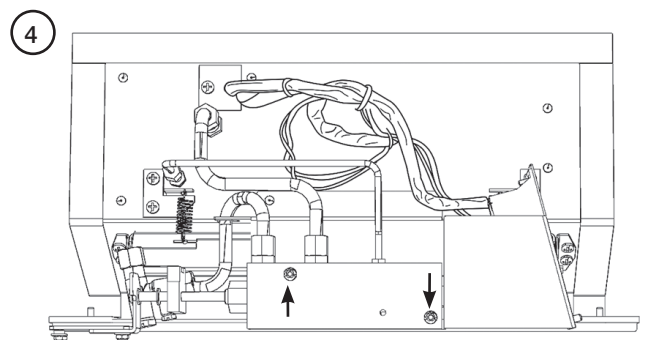

Replace in reverse order.

Check for gas leaks.

MICRO-SWITCH (SLIDE CONTROL MODELS ONLY)

Disconnect the 2 leads from the Micro-Switch, see Diagram 1.

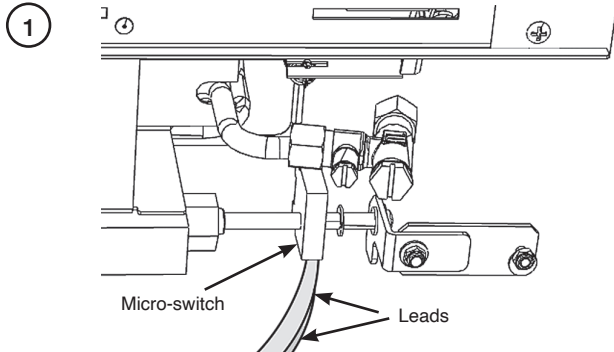

Remove the screw, bracket, washer & spacer from the Micro-Switch spindle, see Diagrams 2 & 3.

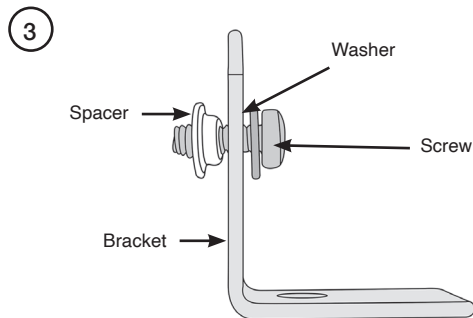
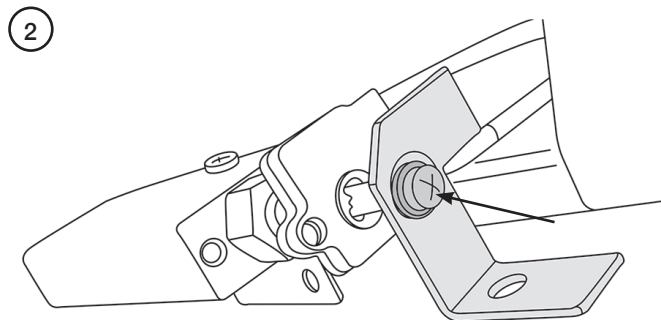

When replacing ensure that the components are assembled in the same order.

Remove the circlip from the spindle, see Diagram 4.

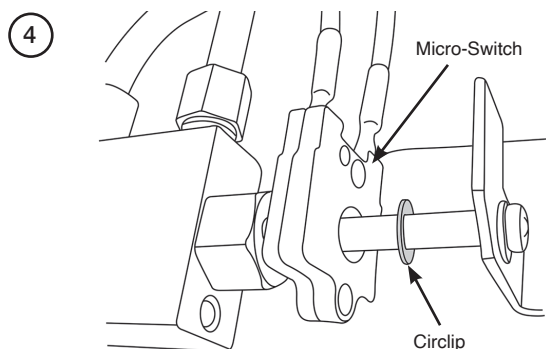

Replace the micro-switch.

Reassemble in reverse order.

MAIN INJECTOR

Undo the compression nut from the feed pipe, see Diagram 1, A.

Undo the lock nut from the injector, see Diagram 1, B.

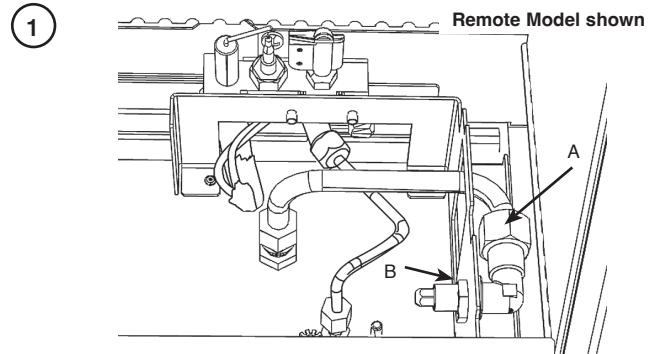

Replace with the correct replacement injector. When ordering, always state the model, gas type and serial number.

Reassemble and turn the gas supply on, check for any leaks.

IGNITION UNIT (SLIDE CONTROL MODELS ONLY)

Remove the battery, see Page 39.

Remove the 2 leads and the pilot ignition lead from the ignition unit.

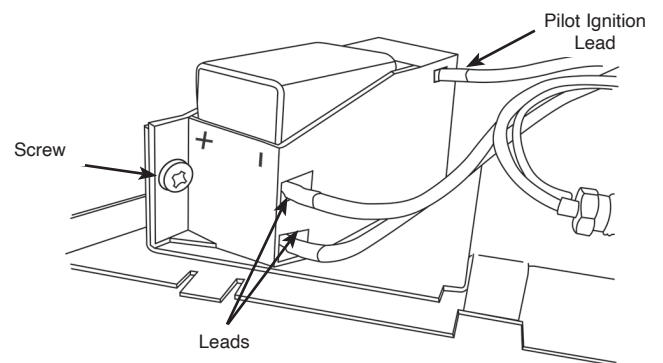

Undo the screw securing the unit in place.

Slide the unit forward to remove.

Replace in reverse order.

BAFFLE & LINERS

The Baffle and Liners do not need to be removed for servicing.

This appliance fitted with twin baffle system, consisting of a front and rear baffle.

FRONT TOP BAFFLE

Undo the 4 screws securing it to the roof of the firebox, see Diagram 1.

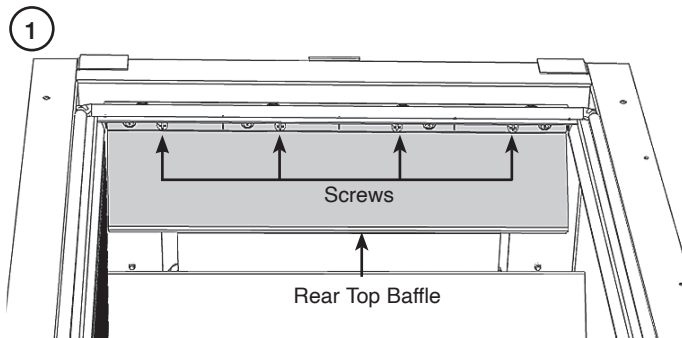

The Front Top Baffle can now be removed by lowering the front edge and pulling forward through the front of the appliance.

TAKE CARE NOT TO DAMAGE THE SIDE PANELS.

Note: When replacing the baffle ensure that the rear edge locates above the rear Top Baffle, see Diagram 1. Take care not to damage the rope seal pins and liners.

LINERS

Once the Front Top Baffle has been placed carefully to one side the liners can then be taken out in the following order.

To remove the Right Hand liner first tilt inwards towards the centre of the firebox before lifting up and pulling out through the front of the firebox, see Diagram 2.

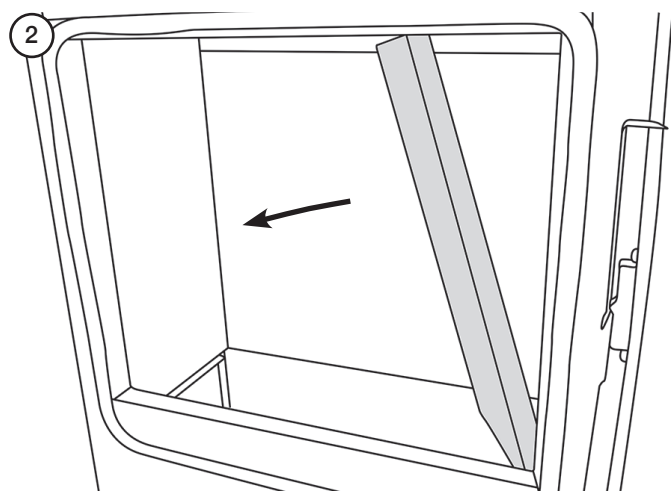

To remove the Left Hand liner first tilt inwards towards the centre of the firebox before lifting up and pulling out through the front of the firebox, see Diagram 2.

The 2 side liners also support the rear liner. Taking out the side liners will allow the rear liner to move forward so ensure it is supported.

Remove the rear liner by carefully leaning the top edge forward and twisting slightly to allow it to be removed through the front of the appliance, see Diagram 3.

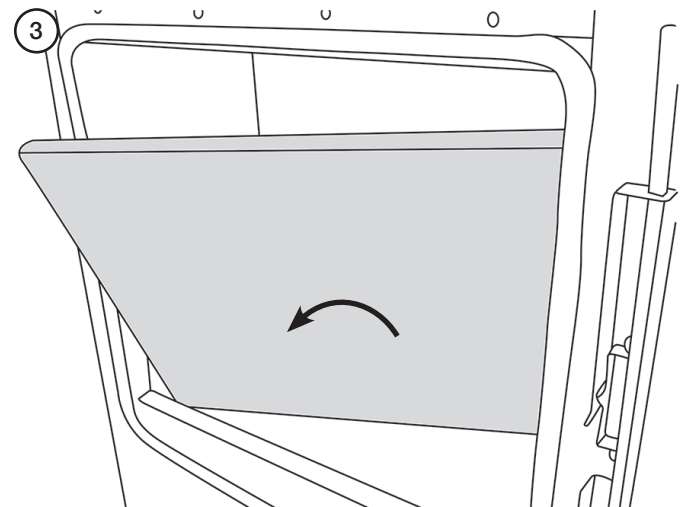

REAR TOP BAFFLE

Once the Front Top Baffle and Liners have been placed carefully to one side the Rear Top Baffle can then be taken out in the following order.

Undo the 4 screws securing it to the roof of the firebox, see Diagram 4.

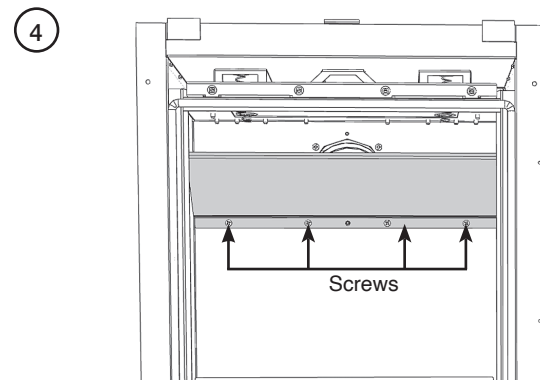

The Rear Top Baffle can now be removed by lowering the front edge and pulling forward through the front of the appliance.

To replace the liners and baffle reverse these procedures.

SPARES LIST - REMOTE CONTROL

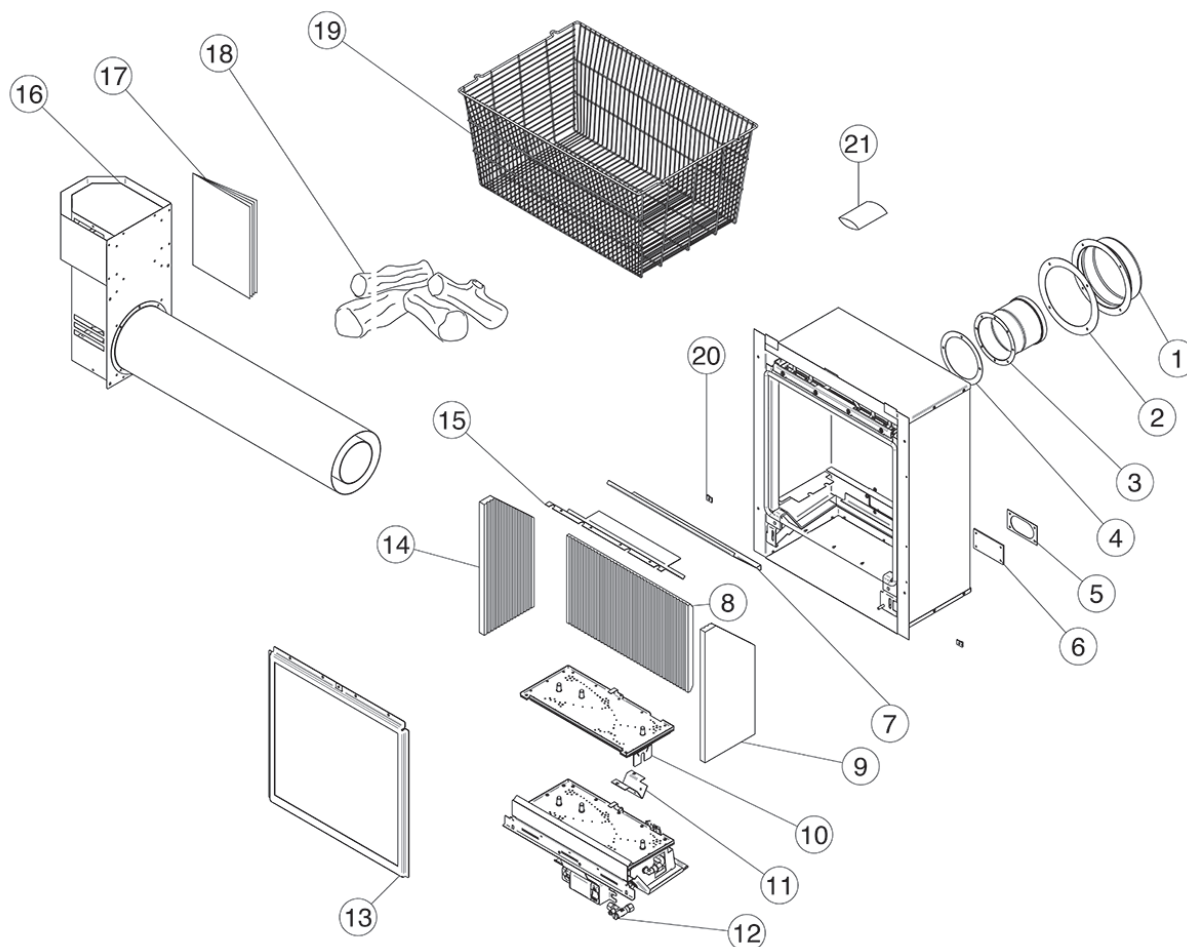

NO	COMPONENT	PART CODE		QTY
		NATURAL GAS	LPG	
1	Outer Spigot	MEC0269		1
2	Outer Flue Spigot Gasket	CE0210		1
3	Inner Spigot	MEC0275		1
4	Inner Flue Spigot Gasket	CE0211		1
5	Inlet Plate	ME3746		1
6	Inlet Silicone Seal	FA0354		1
7	Internal Baffle Rear	GZ14790		1
8	Black Reed Rear Lining	CE1967		1
9	Black Reed RH Lining	CE1966		1
10	Burner Assembly	GZ15411	GZ14540	1
11	Aeration Plate	GZ10405	GZ10409	1

NO	COMPONENT	PART CODE		QTY
		NATURAL GAS	LPG	
12	Engine Assembly	GZ15684N	GZ15684P	1
13	Door Assembly	GZ14017		1
14	Black Reed LH Lining	CE1965		1
15	Top Baffle	GZ14789		1
16	Rear Exit Terminal	MEC0226		1
17	Installation Instructions	PR2756		1
18	Log Set	CE1755		1
19	Terminal Guard	999-159		1
20	Spire Clip	FA0041		2
21	Embaglow	GZ8472		1



Due to continual technical improvements please check online or with your Gazco retailer for the most up to date parts lists.

Only use Genuine Gazco spares when servicing your appliance.
All of our essential spare parts and consumable items are available to purchase from our webshop at www.gazcospares.com.

SPARES LIST - REMOTE CONTROL - BURNER ASSEMBLY

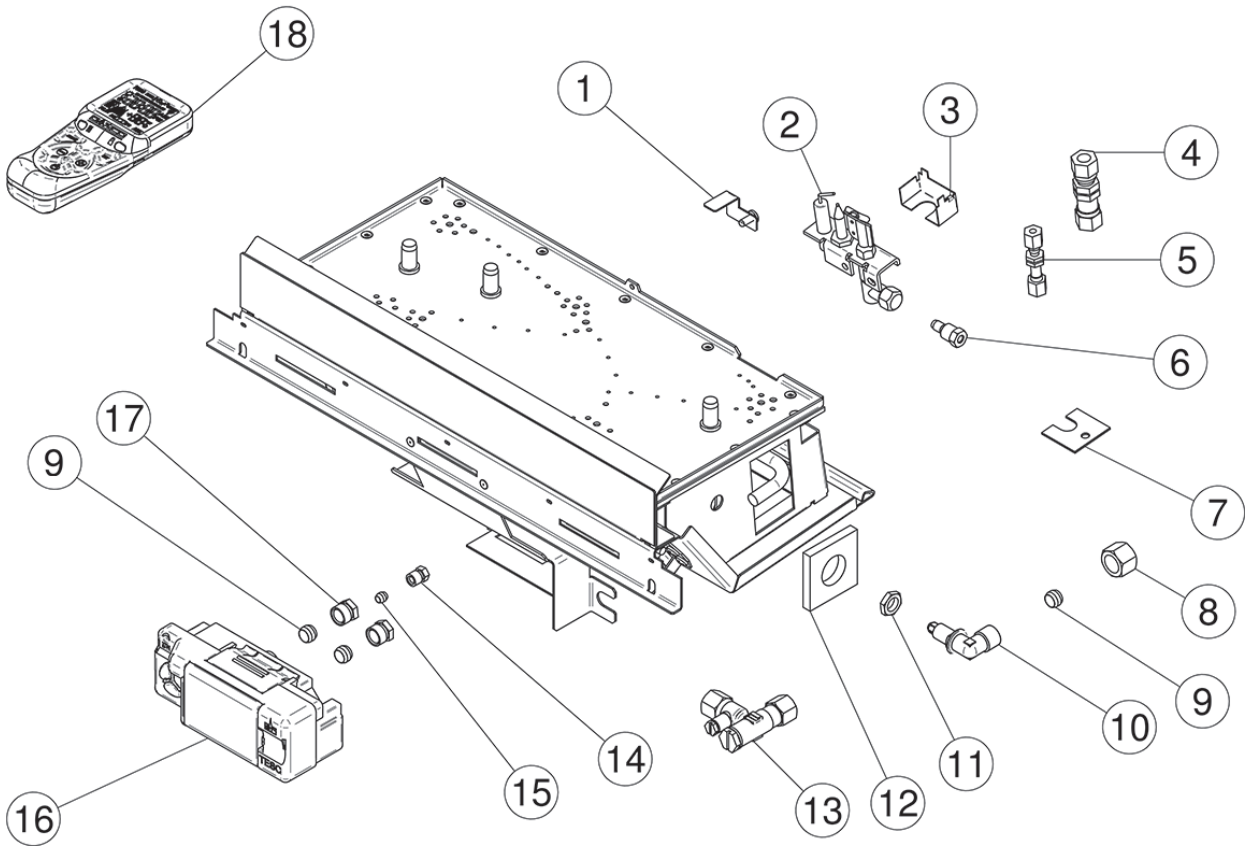

NO.	COMPONENT	PART CODE		QTY
		NATURAL GAS	LPG	
1	Log Support	GZ15302	N/A	1
2	Pilot Unit	PI0090	PI0092	1
3	Lint Arrester Shield	PI0056		1
4	8mm Bulk Head Fitting	FA0271		1
5	4mm Bulk Head Fitting	FA0270		1
6	Shear Nut and Olive	GC0024		1
7	Lead Cover	GZ2020		1
8	1/4" BSP Nut	FA0029		1
9	8mm Olive	FA0011		3

NO.	COMPONENT	PART CODE		QTY
		NATURAL GAS	LPG	
10	Injector	IN0073	IN0056	1
11	1/8" BSP Nut	FA0241		1
12	Rubber Venturi Seal	FA0171		1
13	Inlet Isolation Device	GC0095		1
14	4mm Internal Tube Nut	FA0782		1
15	4mm Olive	FA0781		1
16	Gas Control Valve	GC0182K		1
17	8mm Internal Tube Nut	FA0780		2
18	Handset	EL0807		1



Due to continual technical improvements please check online or with your Gazco retailer for the most up to date parts lists.

Only use Genuine Gazco spares when servicing your appliance.

All of our essential spare parts and consumable items are available to purchase from our webshop at www.gazcospares.com.

SPARES LIST - SLIDE CONTROL

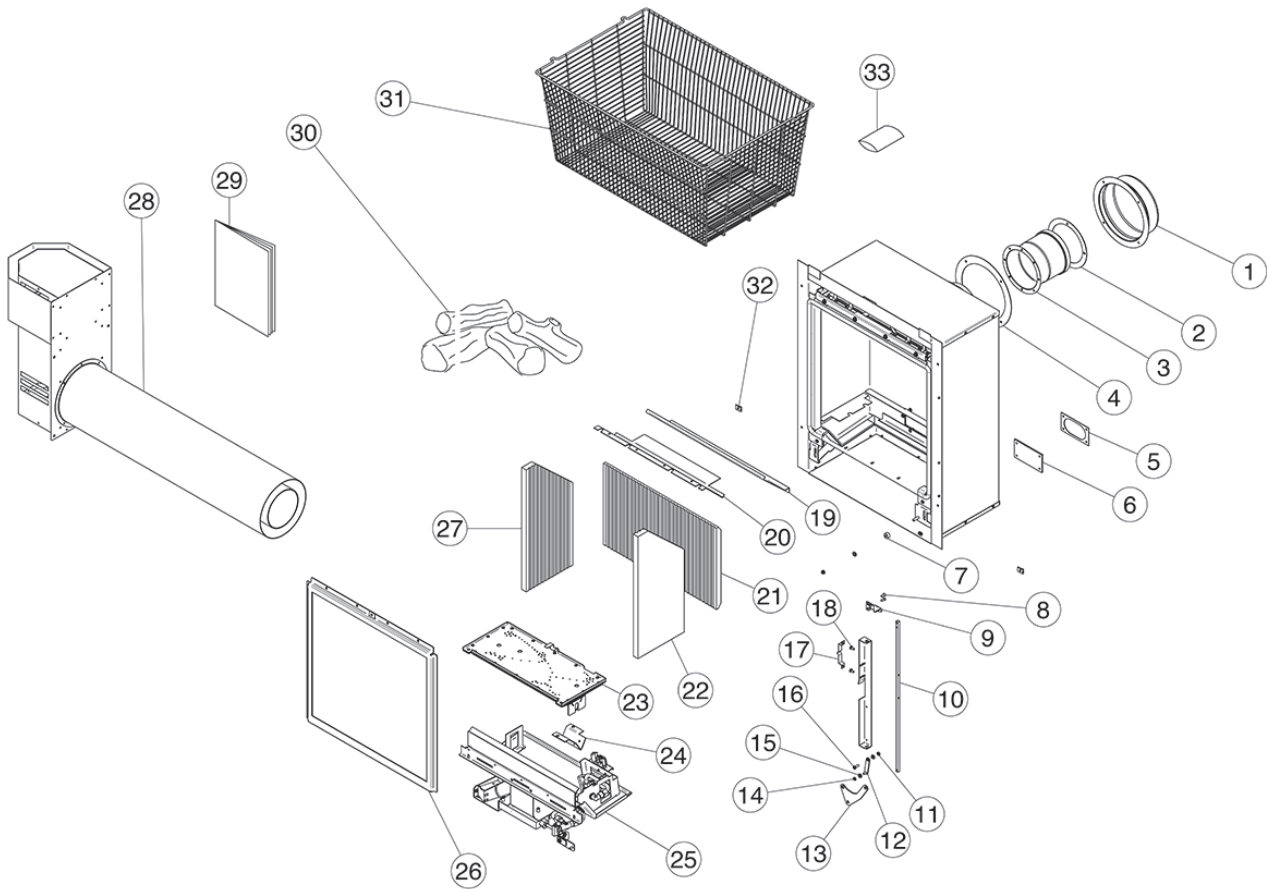

NO	COMPONENT	PART CODE		QTY	NO	COMPONENT	PART CODE		QTY
		NATURAL GAS	LPG				NATURAL GAS	LPG	
1	Outer Spigot	MEC0269		1	17	Spring Clip	GZ11061		1
2	Inner Flue Spigot Gasket	CE0210		1	18	M4 x 6 Pozi Pan Head	FA0694		2
3	Inner Spigot	MEC0275		1	19	Internal Baffle Rear	GZ14790		1
4	Outer Flue Spigot Gasket	CE0211		1	20	Top Baffle	GZ14789		1
5	Inlet Plate	ME3746		1	21	Black Reed Rear Lining	CE1967		1
6	Inlet Silicone Seal	FA0354		1	22	Black Reed RH Lining	CE1966		1
7	Metal Spacer	FA0691		1	23	Burner Assembly	GZ15411	GZ15412	1
8	M4 x 10 CSK Posi Head	FA0330		2	24	Aeration Plate	GZ10405	GZ10409	1
9	Folded Handle	GZ11002		1	25	Engine Assembly	GZ15413N	GZ15413P	1
10	Pushrod	GZ11009		1	26	Door Assembly	GZ14017		1
11	Brass Hex Nut M4	FA0202		1	27	Black Reed LH Lining	CE1965		1
12	Link Plate	GZ10052		1	28	Rear Exit BF Terminal	MEC0226		1
13	Crank Lever	ME11008		1	29	Installation Instructions	PR2756 / PR2537		1
14	M4 Nyloc Nut Zinc Plated	C94323		2	30	Log Set	CE1755		1
15	Circular Clearance Spacer	FA0685		2	31	Terminal Guard	999-159		1
16	M4 x 12 Pan HD Screw	D2150-1412		1	32	Spire Clip	FA0041		2
					33	Embaglow	GZ8472		1



Due to continual technical improvements please check online or with your Gazco retailer for the most up to date parts lists.

Only use Genuine Gazco spares when servicing your appliance.

All of our essential spare parts and consumable items are available to purchase from our webshop at www.gazcospares.com.

SPARES LIST - SLIDE CONTROL - BURNER ASSEMBLY

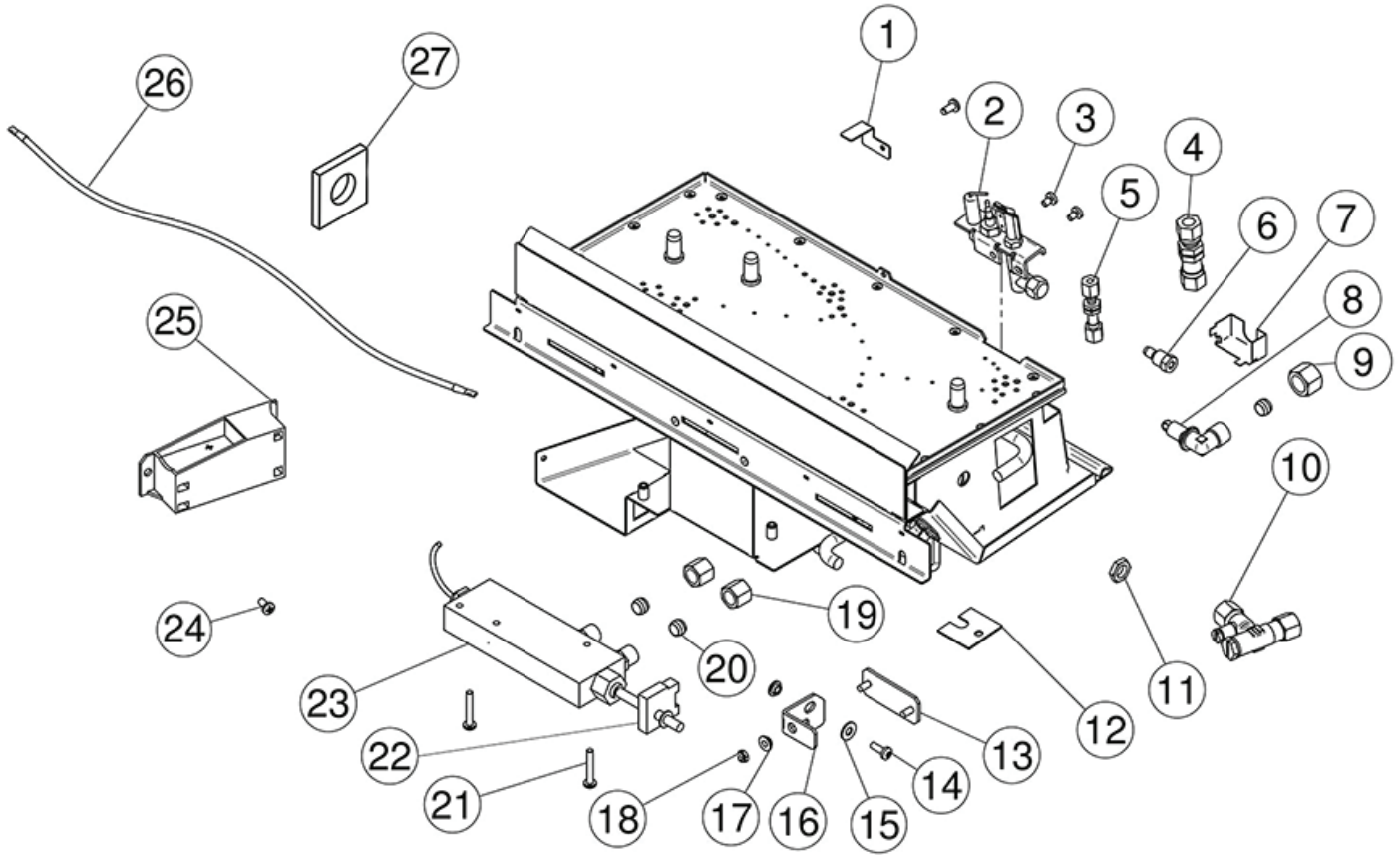

NO	COMPONENT	PART CODE		QTY
		NATURAL GAS	LPG	
1	Log Support	GZ15302	-	1
2	Oxypilot	PI0044	PI0045	1
3	M4 x 6mm S/Steel Tap Tight Screw	FA0154		2
4	8mm Bulk Head Fitting	FA0271		1
5	4mm Bulk Head Fitting	FA0270		1
6	SIT 4mm Shear Off Nut & Olive	GC0024		1
7	Lint Arrester Shield	PI0056		1
8	Injector	Size 161 IN0073	Size 104 IN0056	1
9	1/4" BSP Nut 1	FA0029		1
10	Inlet Isolation Device	GC0095		1
11	1/8 BSP Locknut Brass	FA0241		1
12	Therm/HT Lead Cover PLT	GZ2020		1
13	Bottom Link (39mm CTR)	GZ11577		1

NO	COMPONENT	PART CODE		QTY
		NATURAL GAS	LPG	
14	M4 x 12 Pan HD Screw	D2150-1412		1
15	M5 Large Washer Zinc Plated	FA0705		2
16	Valve Actuator Bracket	GZ11007		1
17	Circular Clearance Spacer M4	FA0685		2
18	M4 Nyloc Nut	C94323		1
19	8mm Nut	FA0122		2
20	8mm Olive	FA0011		3
21	M4 x 25 Pozidrive Head	FA0186		2
22	Micro-Switch Fixing Kit	GC0179		1
23	Control Valve	GC0168		1
24	No 8 x 10mm Black Pozidrive Screw	FA0016		1
25	Slide Control Ignitor	EL0573		1
26	Ignition Lead	EL0578		3
27	Venturi Seal	FA0171		1



Due to continual technical improvements please check online or with your Gazco retailer for the most up to date parts lists.

Only use Genuine Gazco spares when servicing your appliance.

All of our essential spare parts and consumable items are available to purchase from our webshop at www.gazcospares.com.

(EU) 2024/1103 ECODESIGN REGULATION

TABLE 1: INFORMATION REQUIREMENTS FOR GASEOUS FUEL LOCAL SPACE HEATERS

Fuel	Model Identifier(s):		101-014A	101-666A	101-281A	101-516A	
	Indirect heating functionality:		No	No	No	No	
	Direct heat output:		3.3	3.2	3.3	3.3	kW
	Indirect heat output:		N.A.	N.A.	N.A.	N.A.	
	Minimum permissible total flue duct length (vertical + horizontal pipe):		0.1	0.1	0.1	0.1	m
Symbol							Unit
Fuel	Select fuel type:		Gaseous				
	Nitrogen oxides (NOx) emission		120	120	120	120	mg/kWh input (GCV)
Heat Output	Nominal Heat Output	P_{nom}	3.3	3.2	3.3	3.3	kW
	Minimum Heat Output (indicative)	P_{min}	1.8	1.9	1.9	1.9	kW
Useful Efficiency (NCV)	Useful Efficiency at nominal heat output	$\eta_{th,nom}$	86.0	86.0	86.0	86.0	%
	Useful Efficiency at minimum heat output (indicative)	$\eta_{th,min}$	79.3	81.5	79.3	81.5	%
	Seasonal space heating energy efficiency	η_s	75.3	75.3	66.7	66.7	%
Auxiliary Electricity Consumption	At Nominal Heat Output	$e_{l,max}$	0.0	0.0	0.0	0.0	kW
	At Minimum Heat Output	$e_{l,min}$	0.0	0.0	0.0	0.0	kW
Power consumption	In off mode	P_0	0.00	0.00	0.00	0.00	kW
	In standby mode	P_{sm}	0.00	0.00	0.00	0.00	kW
	In idle mode	P_{idle}	0.00	0.00	0.00	0.00	kW
	In networked standby mode	P_{nsm}	0.00	0.00	0.00	0.00	kW
	Standby mode with display of information or status		No	No	No	No	
Permanent Pilot Flame Power consumption (if applicable)		P_{pilot}	N.A.	N.A.	N.A.	N.A.	kW
Type of heat output/room temperature control (select one)			TD	TD	TX	TX	
Key:	NC: single stage heat output, no room temperature control TX: two or more manual stages, no temperature control TM: with mechanic thermostat room temperature control		TE: with electronic room temperature control TD: with electronic room temperature control plus day timer TW: with electronic room temperature control plus week timer				
Other control options (multiple selections possible)							
Room temperature control, with presence detection						No	
Room temperature control, with open window detection						No	
With distance control option						No	
With adaptive start control						No	
With working time limitation						No	
With black bulb sensor						No	

REGULATION (EU) 2015/1186 ENERGY LABELLING – LOCAL SPACE HEATERS PRODUCT FICHE

(a) supplier's name or trademark:	Stovax Gazco Ltd.			
	Logic HE BF Remote Control NG Log	Logic HE BF Remote Control LPG Log	Logic HE BF Slide Control NG Log	Logic HE BF Slide Control LPG Log
(b) supplier's model identifier:	101-014A	101-666A	101-281A	101-516A
(c) the energy efficiency class of the model:	B	B	C	C
(d) the direct heat output in kW:	3.3	3.2	3.3	3.3
(e) the indirect heat output in kW:	N.A.	N.A.	N.A.	N.A.
(f) the energy efficiency index	82%	82%	77%	77%
(g) the useful energy efficiency at: nominal heat output: and at minimum load:	86.0% 79.3%	86.0% 81.5%	86.0% 79.3%	86.0% 81.5%
(h) any specific precautions that shall be taken when the local space heater is assembled, installed or maintained	None	None	None	None

PRODUCT MATERIAL INFORMATION

The following substances, preparations or components should be disposed of or recovered separately from other WEEE in compliance with Article 4 of EU Council Directive 75/442/EEC.

Metal	Steel	Can be taken to a local recycling centre for reuse to reduce waste going to landfill.
	Cast iron	
Glass		Can be taken to a local recycling centre for reuse to reduce waste going to landfill.
Rope seals Black Reed Liners		These items are made from Refractory Ceramic Fibre (RCF), a material which is commonly used for this application. Protective clothing is not required when handling these articles, but it is recommended to follow normal hygiene rules of not smoking, eating or drinking in the work area and always wash hands before eating or drinking. When servicing the appliance it is recommended that the replaced items are not broken up, but are sealed within heavy duty polythene bags and labelled as RCF waste. RCF waste is classed as stable, non-reactive hazardous waste and may be disposed of at a licensed landfill site.
Log Fuel Effects		Log Fuel Effects are not considered hazardous to health, but are non-recyclable and must be disposed of in accordance to the rules in force.
Electrical components	(Fan kits, etc. if applicable)	Dispose of at a local recycling centre in accordance with the WEEE directive.

SERVICE RECORDS

1ST SERVICE

Date of Service
 Next Service Due
 Signed
 Retailer's Stamp/GasSafe Registration Number

3RD SERVICE

Date of Service
 Next Service Due
 Signed
 Retailer's Stamp/GasSafe Registration Number

5TH SERVICE

Date of Service
 Next Service Due
 Signed
 Retailer's Stamp/GasSafe Registration Number

7TH SERVICE

Date of Service
 Next Service Due
 Signed
 Retailer's Stamp/GasSafe Registration Number

9TH SERVICE

Date of Service
 Next Service Due
 Signed
 Retailer's Stamp/GasSafe Registration Number

2ND SERVICE

Date of Service
 Next Service Due
 Signed
 Retailer's Stamp/GasSafe Registration Number

4TH SERVICE

Date of Service
 Next Service Due
 Signed
 Retailer's Stamp/GasSafe Registration Number

6TH SERVICE

Date of Service
 Next Service Due
 Signed
 Retailer's Stamp/GasSafe Registration Number

8TH SERVICE

Date of Service
 Next Due
 Signed
 Retailer's Stamp/GasSafe Registration Number

10TH SERVICE

Date of Service
 Next Service Due
 Signed
 Retailer's Stamp/GasSafe Registration Number

FOR ENQUIRIES IN THE UK (EXCLUDING NI):

**Stovax Gazco Ltd, Spitfire Avenue, Skypark, Clyst Honiton, Exeter, Devon,
England, EX5 2FR Tel: (01392) 261900 E-mail: info@gazco.com**

FOR ENQUIRIES IN EUROPE (INCLUDING NI):

**Stovax Heating Group (NI) Ltd (Comp reg NI675194), 40 Linenhall Street, Belfast, BT2 8BA
DX 400 NR Belfast Tel: +44 (0)1392 261990 E-mail: northernireland@gazco.com**

E & O E

